

# ***POWER STATION ENGINEERING***

---

# ***SOURCES OF ENERGY***

There are mainly two types of sources of energy

1. Conventional Sources of Energy (Non-Renewable Sources of Energy)
2. Non-conventional Sources of Energy (Renewable Sources of Energy).

## **1. CONVENTIONAL SOURCES OF ENERGY**

These resources are finite and exhaustible. Once consumed, these sources cannot be replaced by others. Examples include coal, timber, petroleum, lignite, natural gas, fossil fuels, nuclear fuels etc.

The examples are

(i) fossil fuel (ii) nuclear energy (iii) hydro energy

Have you not seen the filling of fuel in automobiles? What are the fuels that are being used in automobiles? What type of sources of energy are they? Are they non-conventional? Fossil fuel is an invaluable source of energy produced due to chemical changes taking place in the absence of oxygen, in plants and animals that have been buried deep in the earth's crust for many million years. Fossil fuels like coal, petroleum and natural gas are formed in this manner. These are conventional sources of energy. For example, energy from, Petroleum, natural gas, coal, nuclear energy, etc

## **THERMAL POWER**

Thermal generation accounts for about 70% of power generation in India. Thermal energy generation is based on coal, furnace oil and natural gas. Steam cycle, rankin cycle or sterling cycle can be used for energy production. Now clean coal technologies (with 10% ash content) have been used in thermal power plants on commercial scale.

## **NATIONAL THERMAL POWER CORPORATION (NTPC)**

It was incorporated in November 1975 as a public sector undertaking with the main objectives of planning, promoting and organising integrated development of thermal power. Installed capacity of NTPC projects stands at 16000 MW.

## **2. NON-CONVENTIONAL SOURCES OF ENERGY**

These sources are being continuously produced in nature and are not exhaustible. Examples include wood, geothermal energy, wind energy, tidal energy, nuclear fusion, gobar gas, biomass, solar energy etc. The examples are

(i) Solar energy (ii) wind energy (iii) geothermal energy (iv) ocean energy such as tidal energy, wave energy (v) biomass energy such as gobar gas.

It is evident that all energy resources based on fossil fuels has limitations in availability and will soon exhaust. Hence the long term option for energy supply lies only with non-conventional energy sources. These resources are in exhaustible for the next hundreds of thousands of years.

### **52 POWER PLANT ENGINEERING**

The sources which are perennial and give energy continuously and which do not deplete with use are the Non conventional sources of energy.

For example, energy from, solar energy, bio-energy, wind energy, geothermal energy, wave, tidal and OTEC.

## **INTRODUCTION TO VARIOUS NON CONVENTIONAL (RENEWABLE) SOURCES OF ENERGY**

Renewable energy development programme is gaining momentum in India. It has emerged as a viable option to achieve the goal of sustainable development. However, Indian renewable energy programme need more thrust at this stage. India has now the world's largest programme for deployment of renewable energy products and systems, the spread of various renewable energy technologies in the country has been

supported by a variety of incentives and policy measures. Power generation from non-conventional renewable sources has assumed significance in the context of environmental hazards posed by the excessive use of conventional fossil fuels. Renewable energy technologies have proved viable for power generation not so much as a substitute, but as supplement to conventional power generation. Currently renewables contribute over 3500 MW, which represents almost 3.5 percent of the total installed generating capacity of one lakh MW from all sources.

Of this, wind power alone accounts for 1617 MW, while biomass power accounts for 450 MW and small hydros 1438 MW. An additional 4000 MW of power from renewable sources is to be added during the Tenth Five Year Plan period (2002–07) mainly through wind, biomass, small hydros, waste energy and solar energy system. Further, India has set a goal elevating the share of renewable energy sources in power generation up to 10 percent share of new capacity addition or 10,000 MW to come from renewable by 2012.

Today, India has the largest decentralised solar energy programme, the second largest biogas and improved stove programmes and the fifth largest wind energy programme in the world. A substantial manufacturing base, has been created in a variety of renewable energy technologies placing India in a position not only to export technologies; but also offer technical expertise to other countries.

## BIO-GAS

Biogas is a good fuel. Have you thought how this is formed? Biomass like animal excreta, vegetable wastes and weeds undergo decomposition in the absence of oxygen in a biogas plant and form a mixture of gases. This mixture is the biogas. Its main constituent is methane. This is used as a fuel for cooking and Lighting.

### AEROBIC AND ANAEROBIC BIO-CONVERSION PROCESS

There are mainly three aerobic and anaerobic bio-conversion process for the biomass energy applications: There are:

**Bioproducts:** Converting biomass into chemicals for making products that typically are made from petroleum.

**Biofuels:** Converting biomass into liquid fuels for transportation.

**Biopower:** Burning biomass directly, or converting it into a gaseous fuel or oil, to generate electricity.

**Bioproducts.** Whatever products we can make from fossil fuels, we can make using biomass. These bioproducts, or biobased products, are not only made from renewable sources, they also often require less energy to produce than petroleum-based products.

Researchers have discovered that the process for making biofuels releasing the sugars that make up starch and cellulose in plants also can be used to make antifreeze, plastics, glues, artificial sweeteners, and gel for toothpaste.

Other important building blocks for bioproducts include carbon monoxide and hydrogen. When biomass is heated with a small amount of oxygen present, these two gases are produced in abundance. Scientists call this mixture biosynthesis gas. Biosynthesis gas can be used to make plastics and acids, which can be used in making photographic films, textiles, and synthetic fabrics.

When biomass is heated in the absence of oxygen, it forms pyrolysis oil. A chemical called phenol can be extracted from pyrolysis oil. Phenol is used to make wood adhesives, molded plastic, and foam insulation.

**Biofuels.** Unlike other renewable energy sources, biomass can be converted directly into Liquid fuels, biofuels. For our transportation needs (cars, trucks, buses, airplanes, and trains). The two most common types of biofuels are ethanol and biodiesel.

Ethanol is an alcohol, the same found in beer and wine. It is made by fermenting any biomass

high in carbohydrates (starches, sugars, or celluloses) through a process similar to brewing beer. Ethanol is mostly used as a fuel additive to cut down a vehicle's carbon monoxide and other smog-causing emissions. But flexible fuel vehicles, which run on mixtures of gasoline and up to 85% ethanol, are now available.

Biodiesel is made by combining alcohol (usually methanol) with vegetable oil, animal fat, or recycled cooking greases. It can be used as an additive to reduce vehicle emissions (typically 20%) or in its pure form as a renewable alternative fuel for diesel engines.

Other biofuels include methanol and reformulated gasoline components. Methanol, commonly called wood alcohol, is currently produced from natural gas, but could also be produced from biomass.

There are a number of ways to convert biomass to methanol, but the most likely approach is gasification. Gasification involves vaporizing the biomass at high temperatures, then removing impurities from the hot gas and passing it through a catalyst, which converts it into methanol.

Most reformulated gasoline components produced from biomass are pollution reducing fuel additives, such as methyl tertiary butyl ether (MTBE) and ethyl tertiary butyl ether (ETBE).

**Biopower.** Biopower, or biomass power, is the use of biomass to generate electricity. There are six major types of biopower systems: direct fired, cofiring, gasification, anaerobic digestion, pyrolysis, and small, modular.

Most of the biopower plants in the world use direct fired systems. They burn bioenergy feedstocks directly to produce steam. This steam is usually captured by a turbine, and a generator then converts it into electricity. In some industries, the steam from the power plant is also used for manufacturing processes or to heat buildings. These are known as combined heat and power facilities. For instance, wood waste is often used to produce both electricity and steam at paper mills.

Many coal fired power plants can use cofiring systems to significantly reduce emissions, especially sulfur dioxide emissions. Coal firing involves using bioenergy feedstocks as a supplementary energy source in high efficiency boilers.

Gasification systems use high temperatures and an oxygen starved environment to convert biomass into a gas (a mixture of hydrogen, carbon monoxide, and methane). The gas fuels what's called a gas turbine, which is very much like a jet engine, only it turns an electric generator instead of propelling a jet.

The decay of biomass produces a gas methane that can be used as an energy source. In landfills, wells can be drilled to release the methane from the decaying organic matter. Then pipes from each well carry the gas to a central point where it is filtered and cleaned before burning. Methane also can be produced from biomass through a process called anaerobic digestion. Anaerobic digestion involves using bacteria to decompose organic matter in the absence of oxygen.

Methane can be used as an energy source in many ways. Most facilities burn it in a boiler to produce steam for electricity generation or for industrial processes. Two new ways include the use of microturbines and fuel cells. Microturbines have outputs of 25 to 500 kilowatts. About the size of a refrigerator, they can be used where there are space limitations for power production. Methane can also be used as the "fuel" in a fuel cell. Fuel cells work much like batteries but never need recharging, producing electricity as long as there's fuel.

In addition to gas, liquid fuels can be produced from biomass through a process called pyrolysis. Pyrolysis occurs when biomass is heated in the absence of oxygen. The biomass then turns into a liquid called pyrolysis oil, which can be burned like petroleum to generate electricity. A biopower system that uses pyrolysis oil is being commercialized.

Several biopower technologies can be used in small, modular systems. A small, modular system generates electricity at a capacity of 5 megawatts or less. This system is designed for use at the small town level or even at the consumer level. For example, some farmers use the waste from their livestock to provide their farms with electricity. Not only do these systems provide renewable energy, they also help farmers and ranchers meet environmental regulations.

Small, modular systems also have potential as distributed energy resources. Distributed energy resources refer to a variety of small, modular power generating technologies that can be combined to improve the operation of the electricity delivery system.

## RAW MATERIALS

All types of organic wastes which can form slurry are suitable for producing biogas by the process of anaerobic digestion in a biogas plant. Wood and sugar biogases are difficult and time consuming

with this process and incineration may be preferred. The choice of raw material (in feed) is based on availability of the waste. The biogas plant is designed to suit particular type of in feed.  
Dung Water

**Fig. 2.2.** Energy Route of Biogas (Gobar Gas).

Biogas production taken different time period depending upon raw material; temperature; process adopted etc.

The biomass used as a raw material can be classified into the following categories.

Agricultural wastes Agricultural energy crops

Rural animal wastes Aquatic crops

Poultry waste

Butchary waste

Urban waste (garbage) Forest crops

Aquatic wastes

Forest wastes

coconut husk waste

Industrial wastes

Others are poultry waste, piggery waste, sheep, goat, cow, horse dung, Slaughter house waste, coconut shell, husk ,waste garbage, fruit skins and leftovers.

The waste is generated periodically and can be converted into useful biogas. The problem of waste disposal is solved as the sludge is used as manure.

Waste Biogas Plant Biogas

Sluge Manure

The cultivated or harvested biomass is specially grown on land or in sea/lake for obtaining raw materials for biogas production.

## PROPERTIES OF BIO GAS

Main properties of bio gas are:

1. Comparatively simple and can be produced easily.
2. Burns without smoke and without leaving ash as residues.
3. Household wastes and bio-wastes can be disposed of usefully and in a healthy manner.
4. Reduces the use of wood and to a certain extent prevents deforestation.
5. The slurry from the biogas plant is excellent manure.

## BIO GAS PLANT TECHNOLOGY

The important parts of biogas plant are

1. The tank where biomass undergoes decomposition (digester)
2. The tank where biomass is mixed with water (mixing tank)
3. The tank where slurry of biomass is collected (out flow tank)
4. Arrangement to store gas.

Due to the action of bacteria in the absence of oxygen, biogas is produced in the plant. This is collected in the tank. In the gasholder type plant, the cylinder rises up as the gas fills the tank and the storage capacity increases. The gas storage capacity of dome type will be less than that of gasholder type. Residue of biomass (slurry) can be used as good manure.

Biogas plants are built in several sizes, small (0.5 m<sup>3</sup>/day) to very large 2500 m<sup>3</sup>/day). Accordingly, the configurations are simpler to complex.

Biogas plants are classified into following main types.

—Continuous type or batch type.

—Drum type and dome type.

There are various configurations within these types.

## **CONTINUOUS TYPE**

Continuous type biogas plant delivers the biogas continuously and is fed with the biomass regularly. Continuous type biogas plant is of two types.

### **(A) SINGLE STAGE CONTINUOUS TYPE BIOGAS PLANT**

In such a plant Phase-I (acid formation) and Phase-II (methanation) are carried out in the same chamber without barrier. Such plants are simple, economical, easy to operate and control. These plants are generally preferred for small and medium size biogas plants. Single stage plants have lesser rate of gas production than the two stage plant.

### **(B) TWO STATE CONTINUOUS TYPE BIOGAS PLANT**

In such a plant the Phase-I (acid formation) and Phase-II (methane formation) take place in separate chambers. The plant produces more biogas in the given time than the single stage plant. However, the process is complex and the plant is costlier, difficult to operate and maintain. Two stage plant is preferred for larger biogas plant systems.

NON-CONVENTIONAL ENERGY RESOURCES AND UTILISATION 57

## **BATCH TYPE BIOGAS PLANT**

The infeed biomass is fed in batches with large time interval between two consecutive batches. One batch of biomass infeed is given sufficient **retention** time in the digester (30 to 50 days). After completion of the digestion, the residue is emptied and the fresh charge is fed. The fresh biomass charge may be subjected to aeration or nitrogenation after feeding and then the digester covers are closed for the digestion process. Thereafter, the Biogas is derived from the digester after 10 to 15 days. Fermentation continues for 30 to 50 days.

### **Salient Features:**

1. Batch type biogas plant delivers gas intermittently and discontinuously.
2. Batch type biogas plant may have several digesters (reactors) which are fed in a sequential manner and discharged in a sequential manner to obtain the output biogas continuously.
3. Batch type biogas plants have longer digestion time and are therefore more suitable for materials which are difficult for anaerobic digestion (*e.g.* harder, fibrous biomass).
4. Batch type biogas plant needs initial seeding to start the anaerobic fermentation.
5. Batch type biogas plant needs larger volume of the digester to accommodate large volume of the batch. Hence initial cost is higher.
6. Operation and maintenance is relatively more complex. Batch type biomass plants need well organised and planned feeding. Such plants are preferred by European farmers. Such plants are not yet popular in India.

## **FIXED DOME TYPE DIGESTER**

In the fixed dome type digester biogas plant, the digester and gas-collector (gas dome) are enclosed in the same chamber. This type of construction is suitable for batch type biogas plant. The digester is conveniently built at or below ground level in comparatively cooler zone. The construction of the digester is with locally available materials like, bricks, terra-cotta. The pressure inside the digester increases as the biogas is liberated. The biogas gets collected in the upper portion of the digester in a dome shaped cavity. The outlet pipe is provided at the top of the fixed dome. Alternatively the gas collector (gas holder) is a separately installed chamber. The digester tank and gas collector chamber are separated by a water seal tank.

The arrangement of a separate gas collector is preferred as the tapping of gas from the gas holder does not affect the pressure and the digestion process in the main digester. The water seal tank prevents the return of the gas from the gas collector to the digester chamber.

An additional displacement chamber may be provided for providing space to the displacement slurry in the digester due to gas pressure in the upper dome of the fixed type digester. The fixed dome type digester can be fed on daily basis with small quantities of the slurry. The excess slurry in the digester gets accommodated in the displacement chamber. The level of the slurry in the main digester and the displacement collector can vary in accordance with the pressure and volume of the biogas in the fixed type of dome. The pressure in the fixed dome and the displacement gas collector are almost the same as they are connected by the outlet from the main digester.



**Floating Gas Holder Type.** In this design a dome made floats above the slurry in the disaster. The disaster tank is of cylindrical masonry construction. The floating dome is of fabricated steel construction. The dome guide shaft provides the axial guide to the floating dome. As the gas is collected in it. The sliding bearing provides smooth sliding surface and guide to the floating dome. The gas generated in the slurry gets collected in the dome and the dome arises. The water seal tank provides separation between the gas in the dome and the outlet gas.

## WING ENERGY

Wind energy is another potential source of energy. Winds are the motion of air caused by uneven heating of the earth's surface by the sun and rotation of the earth. It generates due to various global phenomena such as 'air-temperature difference' associated with different rates of solar heating. Since the earth's surface is made up of land, desert, water, and forest areas, the surface absorbs the sun's radiation differently. Locally, the strong winds are created by sharp temperature difference between the land and the sea. Wind resources in India are tremendous. They are mainly located near the sea coasts. Its potential in India is estimated to be of  $25 \times 10^3$  mW. According to a news release from American Wind Energy Association the installed wind capacity in India in the year 2000 was 1167 mW and the wind energy production was  $2.33 \times 10^6$  mWh. This is 0.6% of the total electricity production.

NON-CONVENTIONAL ENERGY RESOURCES AND UTILISATION 59

During the day, air above the land heats more quickly than air above water. The hot air over the land expands and rises, and the heavier, cooler air over a body of water rushes in to take its place, creating local winds. At night, the winds are reversed because air-cools more rapidly over land than over water. Similarly, the large atmospheric winds that circle the earth are created because land near the equator is heated more by the sun than land near the North and South Poles.

Today people can use wind energy to produce electricity. Wind is called a renewable energy source because we will never run out of it. Winds are natural phenomena in the atmosphere and have two different origins.

- (1) Planetary winds are caused by daily rotation of earth around its polar axis and unequal temperature between Polar Regions and equatorial regions.
- (2) Local Winds are caused by unequal heating and cooling of ground surface of ocean and lake surfaces during day and night.

## WIND MACHINE FUNDAMENTALS

Throughout history people have harnessed the wind. Over 5,000 years ago, the ancient Egyptians used wind power to sail their ships on the Nile River. Later people built windmills to grind their grain. The earliest known windmills were in Persia (the area now occupied by Iran). The early windmills looked like large paddle wheels. Centuries later, the people in Holland improved the windmill.

They gave it propeller type blades and made it so it could be turned to face the wind. They have been used for pumping water or grinding grain. Windmills helped Holland become one of the world's most industrialized countries by the 17th century. Today, the windmill's modern equivalent — a *wind turbine* — can use the wind's energy to generate electricity.

American colonists used windmills to grind wheat and corn, to pump water, and to cut wood at sawmills.

In this century, people used windmills to generate electricity in rural areas that did not have electric service. When power lines began to transport electricity to rural areas in the 1930s, the electric windmills were used less and less.

Then in the early 1970s, oil shortages created an environment eager for alternative energy sources, paving the way for the re-entry of the electric windmill on the American landscape.

Today's wind machine is very different from yesterday's windmill. Along with the change in name have come changes in the use and technology of the windmill. While yesterday's machines were used primarily to convert the wind's kinetic energy into mechanical power to grind grain or pump water, today's wind machines are used primarily to generate electricity. Like old-fashioned windmills, today's wind machines still use blades to collect the wind's kinetic energy. Windmills work because they slow down the speed of the wind. The wind flows over the airfoil shaped blades causing lift, like the effect on airplane wings, causing them to turn. The blades are connected to a drive shaft that turns an electric generator to produce electricity.

Modern wind machines are still wrestling with the problem of what to do when the wind isn't blowing. Large turbines are connected to the utility power network-some other type of generator picks up the load when there is no wind. Small turbines are often connected to diesel/electric generators or sometimes have a battery to store the extra energy they collect when the wind is blowing hard.

A wind turbine changes the kinetic energy of the wind into rotary motion (or torque) that can do work. It could power a water pump, or turn a generator.

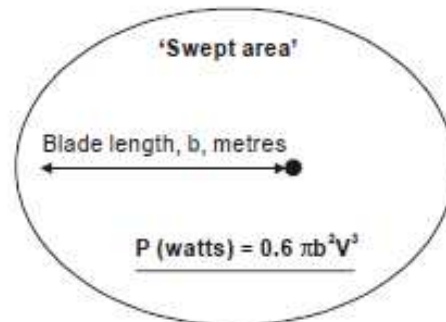

Fig. 2.5

Winds are the motion of air caused by uneven heating of the earth's surface by the sun and rotation of the earth. There is a direct relationship between the swept area of the turbine blades and the turbine's power output (see above). The estimated total power capacity of the winds passing over the land is about  $1e^{15}$  W. But the total exploitable wind power is only  $2e^{13}$  W.

The theoretical wind power can be estimated as:

$$\text{Power density} = 0.6 k \rho \cdot v^3 = 0.6 \pi b^2 v^3$$

where;  $k$  = Energy pattern factor (depends on type of wind)

$\rho$  = Wind density

$v$  = The average wind velocity.

Of the theoretical quantity energy that can be extracted from the wind, large commercial wind turbines are unlikely to get more than 25% of this. Small and less high-tech. designs might only get 15%. But the effect of this equation is that if the wind speed doubles, the power output increases eight-fold. So small increases in wind velocity can create large increases in power output.

The large amounts of energy that are produced at very high wind speeds means that most wind turbines have a pre-designed maximum power output to prevent the machinery ripping itself apart. Large wind turbines rated 150 kW and above are very complex machines. All wind turbines must 'feather' the blades turning them slightly out of the wind as wind speed increases in order to prevent the turbine running away. If this didn't happen, the centripetal force could rip the blades off. But large turbines also have complex automatic gearboxes that keep the generator turning at the optimum speed for power generation. Rarely does the wind blow constantly. This means that the rated output of the turbine will never be achieved as a constant output. On average turbines produce about 30% of their rated capacity as continuous power. So, to compare wind turbines to continuous power sources, you have to multiply the continuous capacity by 3.33 to get the amount of wind turbine capacity required to produce the same power output. For example, a 1,000 mW coal-fired power station would require 3,333 mW of wind capacity to provide the same average power output. As yet there is no efficient form of large scale power storage that would allow the variations in wind turbine output to be evened out

## AEROFOIL DESIGN



The circumferential force, or torque,  $T$  is obtained from

$$T = \frac{P}{\omega} = \frac{P}{\pi DN} \quad \dots(1)$$

where

$T$  = torque, N or lb,

$\omega$  = angular velocity of turbine wheel, m/s

$D$  = diameter of turbine wheel =  $\sqrt{4A/\pi}$ , m

$N$  = wheel revolutions per unit time,  $s^{-1}$

For a turbine operating at power  $P$ , the torque is given by

$$T = \eta \frac{1}{8g_c} \frac{\rho D V_1^3}{N} \quad \dots(2)$$

For a turbine operating at maximum efficiency  $\eta_{\max} = 16/27$ , the torque is given by  $T_{\max}$ :

$$T_{\max} = \frac{2}{27g_c} \frac{\rho D V_1^3}{N}$$

The axial force, or axial thrust, is

$$F_a = \frac{1}{2g_c} \rho A (V_1^2 - V_2^2) = \frac{\pi}{8g_c} \rho D^2 (V_1^2 - V_2^2)$$

The axial force on a turbine wheel operating at maximum efficiency where  $V_2 = 1/3 V_1$  is given by

$$F_{a,\max} = \frac{4}{9g_c} \rho A V_1^2 = \frac{\pi}{9g_c} \rho D^2 V_1^2$$

The axial forces are proportional to the square of the diameter of the turbine wheel which makes them difficult to cope with in extremely large-diameter machines. There is thus an upper limit of diameter that must be determined by design and economical considerations.

The performance of a wind mill rotor stated as coefficient of performance is expressed as:

$$C_p = \frac{A/P_{\max}}{A/(1/2 \rho V^2)}$$

where

$\rho$  = Density of air

$A$  = Swept area

$V$  = Velocity of the wind

Further the tip speed ratio being the function of speed at the tip of the rotor to the wind speed, i.e.  $U/V$  and in most of the parts of India, the wind velocity being low (through the wind energy average around 3 kWh/m<sup>2</sup> day) The exploitation of wind mills in India is feasible. Depending upon the survey of velocity in a region the appropriate value of design parameter may be computed.

## WIND POWER SYSTEMS

Wind machines are just as efficient as coal plants. Wind plants convert 30 percent of the wind's kinetic energy into electricity. A coal-fired power plant converts about 30-35 percent of the heat energy in coal into electricity. It is the capacity factor of wind plants that puts them a step behind other power plants. Capacity factor refers to the capability of a plant to produce energy. A plant with a 100 percent capacity rating would run all day, every day at full power. There would be no down time for repairs or refueling, an impossible dream for any plant. Wind plants have about a 25 percent capacity rating because wind machines only run when the wind is blowing around nine mph or more. In comparison, coal plants typically have a 75 percent capacity rating since they can run day or night, during any season of the year. One wind machine can produce 275-500 thousand kilowatt-hours (kWh) of electricity a year. That is enough electricity for about 50 homes per year.

In this country, wind machines produce about three billion kWh of energy a year. Wind energy

provides 0.12% of the nation's electricity, a very small amount. Still, that is enough electricity to serve more than 300,000 households, as many as in a city the size of San Francisco or Washington, D.C. California produces more electricity from the wind than any other state of USA. It produces 98 percent of the electricity generated from the wind in the United States. Some 16,000 wind machines produce more than one percent of California's electricity. (This is about half as much electricity as is produced by one nuclear power plant.) In the next 15 years, wind machines could produce five percent of California's

electricity. The United States is the world's leading wind energy producer. The U.S. produces about half of the world's wind power. Other countries that have invested heavily in wind power research are Denmark, Japan, Germany, Sweden, The Netherlands, United Kingdom, and Italy. The American Wind Energy Association (AWEA) estimates wind energy could produce more than 10 percent of the nation's electricity within the next 30 years.

So, wind energy may be an important alternative energy source in the future, but it will not be the sole answer to our energy problems. We will still need other energy sources to meet our growing demand for electricity.

### **ECONOMIC ISSUES**

On the economic front, there is a lot of good news for wind energy. First, a wind plant is far less expensive to construct than a conventional energy plant. Wind plants can simply add wind machines as electricity demand increases. Second, the cost of producing electricity from the wind has dropped dramatically in the last two decades. Electricity generated by the wind cost 30 cents per kWh in 1975, but now costs less than five cents per kWh. In comparison, new coal plants produce electricity at four cents per kWh. In the 1970s and 1980s, oil shocks and shortages pushed the development of alternative energy sources. In the 1990s, the push may come from something else, a renewed concern for the earth's environment.

We will use two terms to describe wind energy production: efficiency and capacity factor. Efficiency refers to how much useful energy (electricity, for example) we can get from an energy source. A 100 percent energy efficient machine would change all the energy put into the machine into useful energy. It would not waste any energy. (You should know there is no such thing as a 100 percent energy efficient machine. Some energy is always "lost" or wasted when one form of energy is converted to another. The "lost" energy is usually in the form of heat.)

### **SELECTION OF WIND MILL**

Wind power plants, or wind farms or wind mill as they are sometimes called, are clusters of wind machines used to produce electricity. A wind farm usually has hundreds of wind machines in all shapes and sizes.

Unlike coal or nuclear plants, public utility companies do not own most wind plants. Instead they are owned and operated by business people who sell the electricity produced on the wind farm to electric utilities. These private companies are known as Independent Power Producers.

Operating a wind power plant is not as simple as plunking down machines on a grassy field.

Wind plant owners must carefully plan where to locate their machines. They must consider wind availability (how much the wind blows), local weather conditions, nearness to electrical transmission lines, and local zoning codes.

Wind plants also need a lot of land. One wind machine needs about two acres of land to call its own. A wind power plant takes up hundreds of acres. On the plus side, farmers can grow crops around the machines once they have been installed.

After a plant has been built, there are still maintenance costs. In some states, maintenance costs are offset by tax breaks given to power plants that use renewable energy sources. The Public Utility Regulatory Policies Act, or PURPA; also requires utility companies to purchase electricity from independent power producers at rates that are fair and non-discriminating.

# *Steam Power Plant*

A power plant is assembly of systems or subsystems to generate electricity, *i.e.*, power with economy and requirements. The power plant itself must be useful economically and environmental friendly to the society. The present book is oriented to conventional as well as non-conventional energy generation. While the stress is on energy efficient system regards conventional power systems *viz.*, to increase the system conversion efficiency the supreme goal is to develop, design, and manufacturer the non-conventional power generating systems in coming decades preferably after 2050 AD which are conducive to society as well as having feasible energy conversion efficiency and non-friendly to pollution, keeping in view the pollution act. The subject as a whole can be also stated as modern power plants for power viz electricity generation in 21st century. The word modern means pertaining to time. At present due to energy crisis the first goal is to conserve energy for future while the second step is to develop alternative energy systems including direct energy conversion devices, with the devotion, dedication and determination remembering the phrase, "Delve and Delve Again till wade into".

## **CLASSIFICATION OF POWER PLANTS**

### **Power Plant**

#### **1. Conventional**

- Steam Engines Power Plants
- Steam Turbine Power Plants
- Diesel Power Plants
- Gas Turbine Power Plants
- Hydro-Electric Power Plants
- Nuclear Power Plants Thermoelectric Generator

#### **2. Non-conventional**

Thermoelectric generator  
Fuel-cells Power Plants  
Photovoltaic solar cells Power System  
MHD Power Plants  
Fusion Reactor NPP Power System  
Biogas, Biomass Energy Power System  
Geothermal Energy  
Wind Energy Power System  
Ocean Thermal energy conversion (OTEC)  
Wave and Tidal Wave  
Energy Plantation Scheme

A power plant may be defined as a machine or assembly of equipment that generates and delivers a flow of mechanical or electrical energy. The main equipment for the generation of electric power is generator. When coupling it to a prime mover runs the generator, the electricity is generated. The type of prime mover determines, the type of power plants. The major power plants, which are discussed in this are:

1. Steam power plant
2. Diesel power plant
3. Gas turbine power plant
4. Nuclear power plant

## 5. Hydro electric power plant

The Steam Power Plant, Diesel Power Plant, Gas Turbine Power Plant and Nuclear Power Plants are called **THERMAL POWER PLANT**, because these convert heat into electric energy.

### **BOILERS STEAM GENERATOR**

Boiler is an apparatus to produce steam. Thermal energy released by combustion of fuel is transferred to water, which vaporizes and gets converted into steam at the desired temperature and pressure. The steam produced is used for:

- (i) Producing mechanical work by expanding it in steam engine or steam turbine.
- (ii) Heating the residential and industrial buildings
- (iii) Performing certain processes in the sugar mills, chemical and textile industries.

Boiler is a closed vessel in which water is converted into steam by the application of heat. Usually boilers are coal or oil fired. A boiler should fulfill the following requirements

- (i) **Safety.** The boiler should be safe under operating conditions.
- (ii) **Accessibility.** The various parts of the boiler should be accessible for repair and maintenance.
- (iii) **Capacity.** The boiler should be capable of supplying steam according to the requirements.
- (iv) **Efficiency.** To permit efficient operation, the boiler should be able to absorb a maximum amount of heat produced due to burning of fuel in the furnace.
- (v) It should be simple in construction and its maintenance cost should be low.
- (vi) Its initial cost should be low.
- (vii) The boiler should have no joints exposed to flames.
- (viii) The boiler should be capable of quick starting and loading.

The performance of a boiler may be measured in terms of its evaporative capacity also called power of a boiler. It is defined as the amount of water evaporated or steam produced in kg per hour. It may also be expressed in kg per kg of fuel burnt or kg/hr/m<sup>2</sup> of heating surface.

The boilers can be classified according to the following criteria.

#### **According to flow of water and hot gases.**

1. Water tube.
2. Fire tube.

In water tube boilers, water circulates through the tubes and hot products of combustion flow over these tubes. In fire tube boiler the hot products of combustion pass through the tubes, which are surrounded, by water. Fire tube boilers have low initial cost, and are more compact. But they are more likely to explosion, water volume is large and due to poor circulation they cannot meet quickly the change in steam demand. For the same output the outer shell of fire tube boilers is much larger than the shell of water-tube boiler. Water tube boilers require less weight of metal for a given size, are less liable to explosion, produce higher pressure, are accessible and can response quickly to change in steam demand. Tubes and drums of water-tube boilers are smaller than that of fire-tube boilers and due to smaller size of drum higher pressure can be used easily. Water-tube boilers require lesser floor space. The efficiency of water-tube boilers is more.

#### **Water tube boilers are classified as follows.**

1. Horizontal straight tube boilers
  - (a) Longitudinal drum (b) Cross-drum.
2. Bent tube boilers
  - (a) Two drum (b) Three drum

- (c) Low head three drum (d) Four drum.  
3. Cyclone fired boilers

**Various advantages of water tube boilers are as follows.**

- (i) High pressure of the order of 140 kg/cm<sup>2</sup> can be obtained.
- (ii) Heating surface is large. Therefore steam can be generated easily.
- (iii) Large heating surface can be obtained by use of large number of tubes.
- (iv) Because of high movement of water in the tubes the rate of heat transfer becomes large resulting into a greater efficiency.

**Fire tube boilers are classified as follows.**

1. External furnace:

- (i) Horizontal return tubular
- (ii) Short fire box
- (iii) Compact.

2. Internal furnace:

- (i) Horizontal tubular
  - (a) Short firebox (b) Locomotive (c) Compact (d) Scotch.
- (ii) Vertical tubular.
  - (a) Straight vertical shell, vertical tube
  - (b) Cochran (vertical shell) horizontal tube.

**Various advantages of fire tube boilers are as follows.**

- (i) Low cost
- (ii) Fluctuations of steam demand can be met easily
- (iii) It is compact in size.

**According to position of furnace.**

- (i) Internally fired (ii) Externally fired

In internally fired boilers the grate combustion chamber are enclosed within the boiler shell whereas in case of externally fired boilers and furnace and grate are separated from the boiler shell.

**According to the position of principle axis.**

- (i) Vertical (ii) Horizontal (iii) Inclined.

**According to application.**

- (i) Stationary (ii) Mobile, (Marine, Locomotive).

**According to the circulating water.**

- (i) Natural circulation (ii) Forced circulation.

**According to steam pressure.**

- (i) Low pressure (ii) Medium pressure (iii) Higher pressure.



## Cochran Boiler

This boiler consists of a cylindrical shell with its crown having a spherical shape. The furnace is also hemispherical in shape. The grate is also placed at the bottom of the furnace and the ash-pit is located below the grate. The coal is fed into the grate through the fire door and ash formed is collected in the ash-pit located just below the grate and it is removed manually. The furnace and the combustion chamber are connected through a pipe. The back of the combustion chamber is lined with firebricks. The hot gases from the combustion chamber flow through the nest of horizontal fire tubes (generally 6.25 cm in external diameter and 165 to 170 in number). The passing through the fire tubes transfers a large portion of the heat to the water by convection. The flue gases coming out of fire tubes are finally discharged to the atmosphere through chimney. The spherical top and spherical shape of firebox are the special features of this boiler. These shapes require least material for the volume. The hemi spherical crown of the boiler shell gives maximum strength to withstand the pressure of the steam inside the boiler. The hemi-spherical crown of the fire box is advantageous for resisting intense heat. This shape is also advantageous for the absorption of the radiant heat from the furnace.

Coal or oil can be used as fuel in this boiler. If oil is used as fuel, no grate is provided but the bottom of the furnace is lined with firebricks. Oil burners are fitted at a suitable location below the fire door. A manhole near the top of the crown of shell is provided for cleaning. In addition to this, a number of hand-holes are provided around the outer shell for cleaning purposes. The smoke box is provided with doors for cleaning of the interior of the fire tubes.

The airflow through the grate is caused by means of the draught produced by the chimney. A damper is placed inside the chimney (not shown) to control the discharge of hot gases from the chimney and thereby the supply of air to the grate is controlled. The chimney may also be provided with a steam nozzle (not shown); to discharge the flue gases faster through the chimney. The steam to the nozzle is supplied from the boiler.

The outstanding features of this boiler are listed below:

1. It is very compact and requires minimum floor area.
2. Any type of fuel can be used with this boiler.
3. It is well suited for small capacity requirements.
4. It gives about 70% thermal efficiency with coal firing and about 75% with oil firing.
5. The ratio of grate area to the heating surface area varies from 10: 1 to 25: 1.

It is provided with all required mountings. The function of each is briefly described below:

**1. Pressure Gauge.** This indicates the pressure of the steam in the boiler.

**2. Water Level Indicator.** This indicates the water level in the boiler. The water level in the boiler should not fall below a particular level otherwise the boiler will be overheated and the tubes may burn out.

**3. Safety Valve.** The function of the safety valve is to prevent the increase of steam pressure in the boiler above its design pressure. When the pressure increases above design pressure, the valve opens and discharges the steam to the atmosphere. When this pressure falls just below design pressure, the valve closes automatically. Usually the valve is spring controlled.

**4. Fusible Plug.** If the water level in the boiler falls below a predetermined level, the boiler shell and tubes will be overheated. And if it is continued, the tubes may burn, as the water cover will be removed. It can be prevented by stopping the burning of fuel on the grate. When the temperature of the shell increases above a particular level, the fusible plug, which is mounted over the grate as shown in the Fig. 4.1, melts and forms an opening. The high-pressure steam pushes the remaining water through this hole on the grate and the fire is *extinguished*.

**5. Blow-off Cock.** The water supplied to the boiler always contains impurities like mud, sand and, salt. Due to heating, these are deposited at the bottom of the boiler, and if they are not removed, they are accumulated at the bottom of the boiler and reduce its capacity and heat transfer rates. Also the salt content will go on increasing due to evaporation of water. These deposited salts are removed with the help of blow off cock. The blow-off cock is located at the bottom of the boiler as shown in the figure and is operated only when the boiler is running. When the blow-off cock is opened during the running of the boiler, the high-pressure steam pushes the water and the collected material at the bottom is blown out. Blowing some water out also reduces the concentration of the salt. The blow-off cock is operated after every 5 to 6 hours of working for few minutes. This keeps the boiler clean.

**6. Steam Stop Valve.** It regulates the flow of steam supply outside. The steam from the boiler first enters into an anti-priming pipe where most of the water particles associated with steam are removed.

**7. Feed Check Valve.** The high pressure feed water is supplied to the boiler through this valve. This valve opens towards the boiler only and feeds the water to the boiler. If the feed water pressure is less than the boiler steam pressure then this valve remains closed and prevents the back flow of steam through the valve.

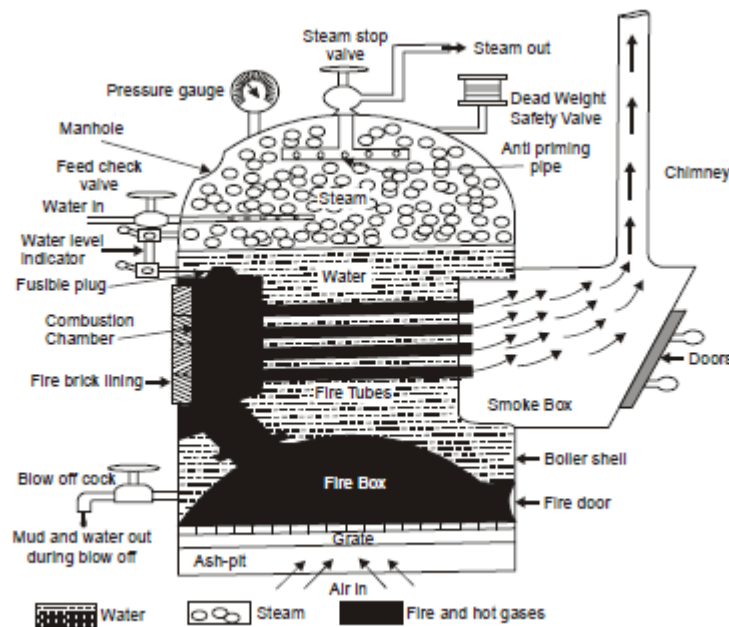

**Cochran Boiler**

It is stationary fire tube, internally fired, horizontal, natural circulation boiler. This is a widely used boiler because of its good steaming quality and its ability to burn coal of inferior quality. These boilers have a cylindrical shell 2 m in diameters and its length varies from 8 m to 10 m. It has two large internal flue tubes having diameter between 80 cm to 100 cm in which the grate is situated. This boiler is set in brickwork forming external flue so that the external part of the shell forms part of the heating surface.

## Lancashire boiler

The main features of the Lancashire boiler with its brickwork shelling are shown in figure. The boiler consists of a cylindrical shell and two big furnace tubes pass right through this. The brick setting forms one bottom flue and two side flues. Both the flue tubes, which carry hot gases, lay below the water level as shown in the Fig.

The grates are provided at the front end of the main flue tubes of the boiler and the coal is fed to the grates through the fire doors. A low firebrick bridge is provided at the end of the grate, as shown, to prevent the flow of coal and ash particles into the interior of the furnace tubes. Otherwise, the ash and coal particles carried with gases form deposits on the interior of the tubes and prevent the heat transfer to the water. The firebrick bridge also helps in deflecting the hot gases upward to provide better heat transfer:

The hot gases leaving the grate pass up to the back end of the tubes and then in the downward direction. They move through the bottom flue to the front of the boiler where they are divided into two and pass to the side flues as shown in the figure. Then they move along the two-side flues and come to the chimney as shown in the figure.

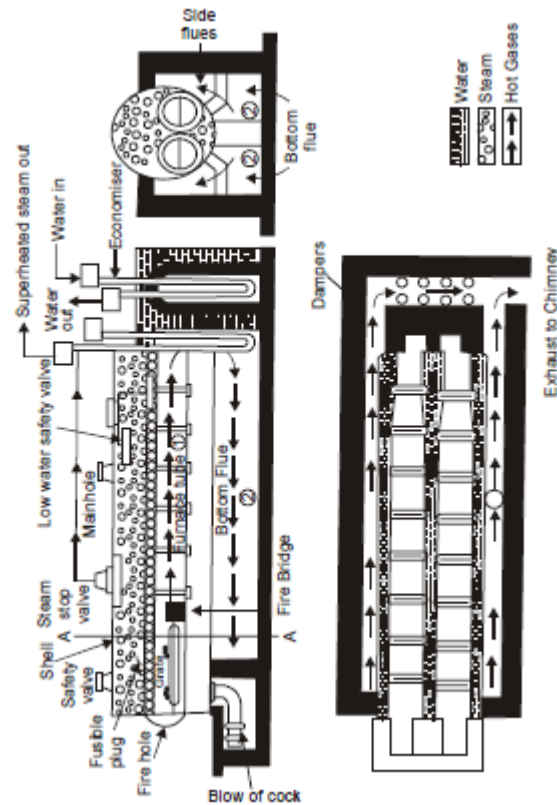

**Lancashire boiler**

With the help of this arrangement of the flow passages of the gases, the bottom of the shell is first heated and then its sides. The heat is transferred to the water through surfaces of the two flue tubes (which remain in water) and bottom part and sides of the main shell. This arrangement increases the heating surface to a large extent.

Dampers in the form of sliding doors are placed at the end of side flues to control the flow of gases. This regulates the combustion rate as well as steam generation rate. These dampers are operated by chains passing over a pulley at the front of the boiler. This boiler is fitted with usual mountings. The pressure gauge and water level indicator are provided at the front whereas steam stop valve, safety valve, low water and high steam safety valve and manhole are provided on the top of the shell.

The blow-off cock is situated beneath the front portion of the boiler shell for the removal of sediments and mud. It is also used to empty the water in the boiler whenever required for inspection. The fusible plugs are mounted on the top of the main flues just over the grates as shown in the figure to prevent the overheating of boiler tubes by extinguishing the fire when the water level falls below a particular level. A low water level alarm is usually mounted in the boiler to give a warning in case the water level going below the precast value.

A feed check valve with a feed pipe is fitted on the front end plate. The feed pipe projecting into the boiler is perforated so that the water is uniformly distributed into the shell.

The outstanding features of this boiler are listed below:

1. Its heating surface area per unit volume at the boiler is considerably large.
2. Its maintenance is easy.
3. It is suitable where a large reserve of hot water is needed. This boiler due to the large reserve capacity can easily meet load fluctuations.
4. Super-heater and economizer can be easily incorporated into the system, therefore; overall efficiency of the boiler can be considerably increased (80-85%).

The super-heater is placed at the end of the main flue tubes. The hot gases before entering the bottom flue are passed over the super-heater tubes as shown in the figure and the steam drawn through the steam stop-valve are passed through the super-heater. The steam passing through the super-heater absorbs heat from hot gases and becomes superheated.

The economizer is placed at the end of side flues before exhausting the hot gases to the chimney. The water before being fed into the boiler through the feed check valve is passed through the economizer. The feed water is heated by absorbing the heat from the exhaust gases, thus leading to better boiler efficiency. Generally, a chimney is used to provide the draught.

## **Locomotive boiler**

Locomotive boiler is a horizontal fire tube type mobile boiler. The main requirement of this boiler is that it should produce steam at a very high rate. Therefore, this boiler requires a large amount of heating surface and large grate area to burn coal at a rapid rate. Providing provides the large heating surface area a large number of fire tubes and heat transfer rate is increased by creating strong draught by means of steam jet.

A modern locomotive boiler is shown in Fig. It consists of a shell or barrel of 1.5 meter in diameter and 4 meters in length. The cylindrical shell is fitted to a rectangular firebox at one end and smoke box at the other end. The coal is manually fed on to the grates through the fire door. A brick arch as shown in the figure deflects the hot gases, which are generated due to the burning of coal. The firebox is entirely surrounded by narrow water spaces except for the fire hole and the ash-pit. The deflection of hot gases with the help of brick arch prevents the flow of ash and coal particles with the gases and it also helps for heating the walls of the firebox properly and uniformly. It also helps in igniting the volatile matter from coal. The walls of the firebox work like an economizer. The ash-pit, which is situated below the firebox, is fitted with dampers at its front and back end shown in the figure to control the flow of air to the grate.

The hot gases from the firebox are passed through the fire tubes to the smoke box as shown in the figure. The gases coming to smoke box are discharged to the atmosphere through a short chimney with the help of a steam jet. All the fire tubes are fitted in the main shell. Some of these tubes (24 in number).

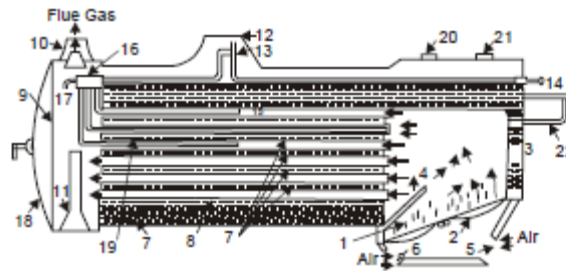

## Locomotive boiler

are of larger diameter (13 cm diameter) fitted at the upper part of the shell and others (nearly 160 tubes) of 4.75 cm in diameter are fitted into the lower part of the shell. The shell contains water surrounding all the tubes. The top tubes are made of larger diameter to accommodate the super-heater tubes. Absorbing heat from the hot gases flowing over the tubes superheats the steam passing through the super-heater tubes. The steam generated in the shell is collected over the water surface. A dome-shaped chamber, known as steam dome, is fitted on the top of the shell. The dome helps to reduce the priming as the distance of the steam entering into the dome and water level is increased. The steam in the shell flows through a pipe mounted in the steam dome as shown in the figure into the steam header which is divided into two parts. One part of the steam header is known as saturated steam header and the other part is known as superheated steam header. The saturated wet steam through the steam pipe enters into the saturated steam header and then it is passed through the super-heater tubes as shown in the figure. The superheated steam coming out of super-heater tubes is collected in the superheated header and then fed to the steam engines. A stop valve serving also as a regulator for steam flow is provided inside a cylindrical steam dome as shown in the figure. This is operated by the driver through a regulator shaft passing from the front of the boiler.

The supply of air to the grate is obtained by discharging the exhaust steam from the engine through a blast pipe which is placed below the chimney. The air-flow caused by this method is known as induced draught. A large door at the front end of the smoke box is provided which can be opened for cleaning the smoke box and fire tubes. The height of the chimney must be low to facilitate the locomotive to pass through tunnels and bridges. Because of the short chimney, artificial draught has to be created to drive out the hot gases. The draught is created with the help of exhaust steam when locomotive is moving and with the help of live steam when the locomotive is stationary. The motion of the locomotive helps not only to increase the draught, but also to increase the heat transfer rate.



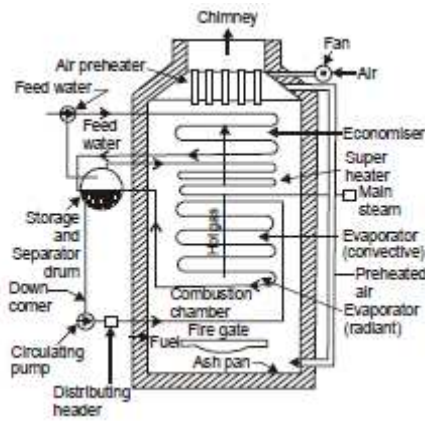
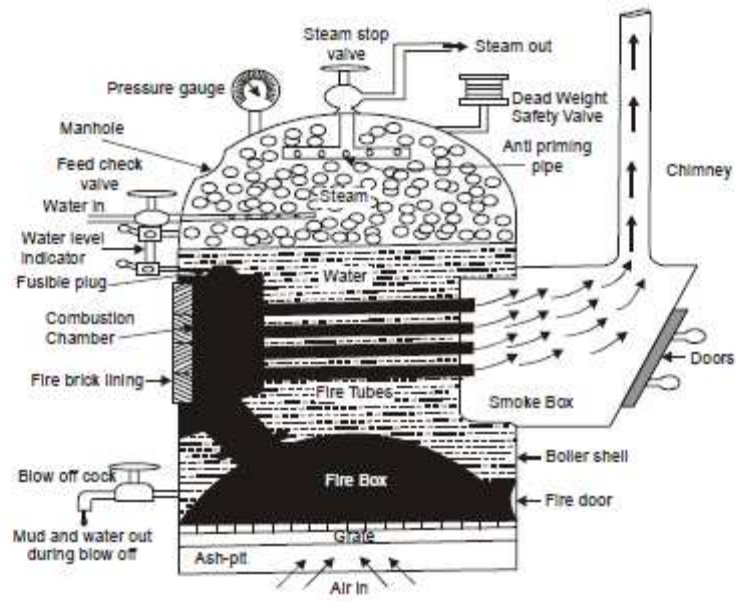

# **MODULE-II**

## **Steam Power Plant Cycles**

### **Classification of Power plant Cycle**

Power plants cycle generally divided in to the following groups,

- (1) Vapour Power Cycle  
(Carnot cycle, Rankine cycle, Regenerative cycle, Reheat cycle, Binary vapour cycle)
- (2) Gas Power Cycles  
(Otto cycle, Diesel cycle, Dual combustion cycle, Gas turbine cycle.)

#### **1. CARNOT CYCLE**

This cycle is of great value to heat power theory although it has not been possible to construct a practical plant on this cycle. It has high thermodynamics efficiency.

It is a standard of comparison for all other cycles. The thermal efficiency ( $\eta$ ) of Carnot cycle is as follows:

$$\eta = (T_1 - T_2)/T_1$$

where,  $T_1$  = Temperature of heat source

$T_2$  = Temperature of receiver

#### **2. RANKINE CYCLE**

Steam engine and steam turbines in which steam is used as working medium follow Rankine cycle. This cycle can be carried out in four pieces of equipment joint by pipes for conveying working medium as shown in Fig. 1.1. The cycle is represented on Pressure Volume P-V and S-T diagram as shown in Figs. 1.2 and 1.3 respectively.

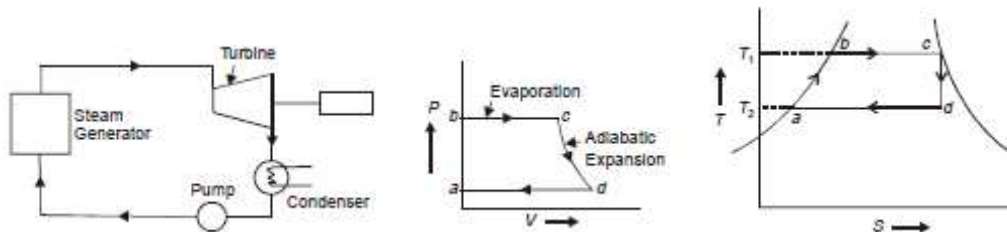

#### **3. REHEAT CYCLE**

In this cycle steam is extracted from a suitable point in the turbine and reheated generally to the original temperature by flue gases. Reheating is generally used when the pressure is high say above 100 kg/cm<sup>2</sup>. The various advantages of reheating are as follows:

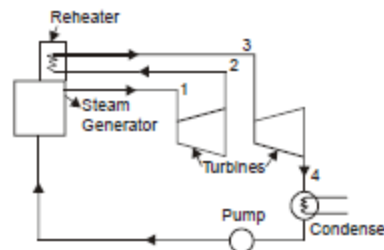

- (i) It increases dryness fraction of steam at exhaust so that blade erosion due to impact of water particles is reduced.
- (ii) It increases thermal efficiency.
- (iii) It increases the work done per kg of steam

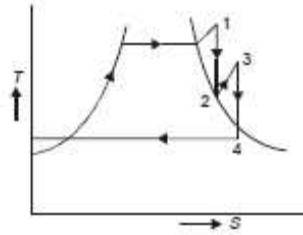

and this results in reduced size of boiler.

The disadvantages of reheating are as follows:

- (i) Cost of plant is increased due to the reheater and its long connections.
- (ii) It increases condenser capacity due to increased dryness fraction.

Fig. 1.4 shows flow diagram of reheat cycle. First turbine is high-pressure turbine and second turbine is low pressure (L.P.) turbine. This cycle is shown on T-S (Temperature entropy) diagram (Fig. 1.5).

If,

$H_1$  = Total heat of steam at 1

$H_2$  = Total heat of steam at 2

$H_3$  = Total heat of steam at 3

$H_4$  = Total heat of steam at 4

$H_{w4}$  = Total heat of water at 4

$$\text{Efficiency} = \frac{(H_1 - H_2) + (H_3 - H_4)}{(H_1 + (H_3 - H_2) - H_{w4})}$$

#### 4. REGENERATIVE CYCLE (FEED WATER HEATING)

The process of extracting steam from the turbine at certain points during its expansion and using this steam for heating for feed water is known as Regeneration or Bleeding of steam. The arrangement of bleeding the steam at two stages is shown in the Figure.

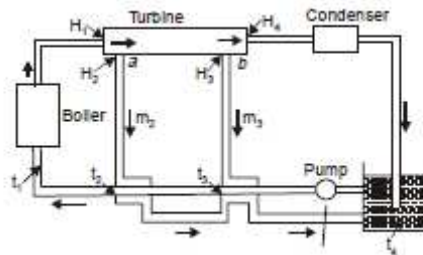

Let,

$m_2$  = Weight of bled steam at a per kg of feed water heated

$m_3$  = Weight of bled steam at b per kg of feed water heated

$H_1$  = Enthalpies of steam and water in boiler

$H_{w1}$  = Enthalpies of steam and water in boiler

$H_2, H_3$  = Enthalpies of steam at points a and b

$t_2, t_3$  = Temperatures of steam at points a and b

$H_4, H_{w4}$  = Enthalpy of steam and water exhausted to hot well.

Work done in turbine per kg of feed water between entrance and a

$$= H_1 - H_2$$

$$\text{Work done between a and b} = (1 - m_2)(H_2 - H_3)$$

$$\text{Work done between } b \text{ and exhaust} = (1 - m_2 - m_3)(H_3 - H_4)$$

$$\text{Total heat supplied per kg of feed water} = H_1 - H_{w2}$$

$$\text{Efficiency } (\eta) = \frac{\text{Total work done}}{\text{Total heat supplied}}$$

$$= \frac{\{(H_1 - H_2) + (1 - m_2)(H_2 - H_3) + (1 - m_2 - m_3)(H_3 - H_4)\}}{(H_1 - H_{w2})}$$

### 5. BINARY VAPOUR CYCLE

In this cycle two working fluids are used. Fig. 1.7 shows Elements of Binary vapour power plant. The mercury boiler heats the mercury into mercury vapours in a dry and saturated state. These mercury vapours expand in the mercury turbine and then flow through heat exchanger where they transfer the heat to the feed water, convert it into steam. The steam is passed through the steam super heater where the steam is super-heated by the hot flue gases. The steam then expands in the steam turbine.

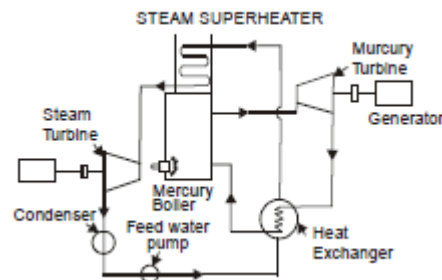

### 6. REHEAT-REGENERATIVE CYCLE

In steam power plants using high steam pressure reheat regenerative cycle is used. The thermal efficiency of this cycle is higher than only reheat or regenerative cycle. Fig. 1.8 shows the flow diagram of reheat regenerative cycle. This cycle is commonly used to produce high pressure steam (90 kg/cm<sup>2</sup>) to increase the cycle efficiency.

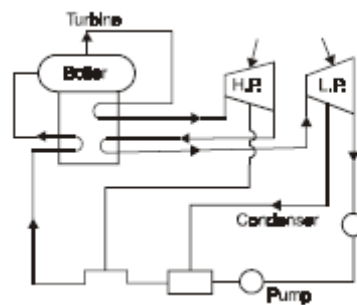

## Steam Prime Mover

The prime mover converts the natural resources of energy into power or electricity. The prime movers to be used for generating electricity could be diesel engine, steam engine, steam turbines, gas turbines, and water turbine. Since we know that, a power plant generated a flow of mechanical or electrical energy by means of generators. When coupling runs the generator, then the generator is a prime mover.

In case of steam power plant, the prime movers is steam engine or steam turbine, which is called, steam prime movers. Presently, the steam turbine has totally replaced steam engine. The steam is generated in a boiler and is then expanded in the turbine. The output of the steam turbine is utilized to run the generator. The fuel used in the boiler is coal or oil.

Thermal efficiency of a closed cycle power developing system using steam as working fluid and working on Carnot cycle is given by an expression  $(T_1 - T_2)/T_1$ . This expression of efficiency shows that the efficiency increases with an increase in temperature  $T_1$  and decrease in temperature  $T_2$ . The maximum temperature  $T_1$  of the steam supplied to a steam prime mover is limited by material considerations. The temperature  $T_2$  (temperature at which heat is rejected) can be reduced to the atmospheric temperature if the exhaust of the steam takes place below atmospheric pressure. If the exhaust is at atmospheric pressure, the heat rejection is at  $100^\circ\text{C}$ .

Low exhaust pressure is necessary to obtain low exhaust temperature. But the steam cannot be exhausted to the atmosphere if it is expanded in the engine or turbine to a pressure lower than the atmospheric pressure. Under this condition, the steam is exhausted into a vessel known as condenser where the pressure is maintained below the atmosphere by continuously condensing the steam by means of circulating cold water at atmospheric temperature.

*A closed vessel in which steam is condensed by abstracting the heat and where the pressure is maintained below atmospheric pressure is known as a condenser.*

The efficiency of the steam plant is considerably increased by the use of a condenser. In large turbine plants, the condensate recovery becomes very important and this is also made possible by the use of condenser.

The steam condenser is one of the essential components of all modern steam power plants. Steam condenser are of two types:

### 1. Surface condenser. 2. Jet condensers

In surface condensers there is no direct contact between the steam and cooling water and the condensate can be re-used in the boiler: In such condenser even impure water can be used for cooling purpose whereas the cooling water must be pure in jet condensers. Although the capital cost and the space needed is more in surface condensers but it is justified by the saving in running cost and increase in efficiency of plant achieved by using this condenser. Depending upon the position of condensate extraction pump, flow of condensate and arrangement of tubes the surface condensers may be classified as follows:

(i) **Down flow type.** Fig.1 shows a sectional view of dawn flow condenser. Steam enters at the top and flows downward. The water flowing through the tubes in one direction lower half comes out in the opposite direction in the upper half Fig.2 shows a longitudinal section of a two pass down-flow condenser.



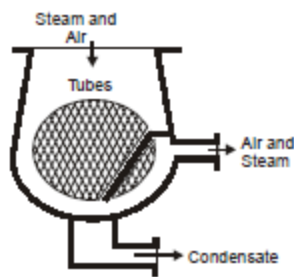

**Fig. 1**

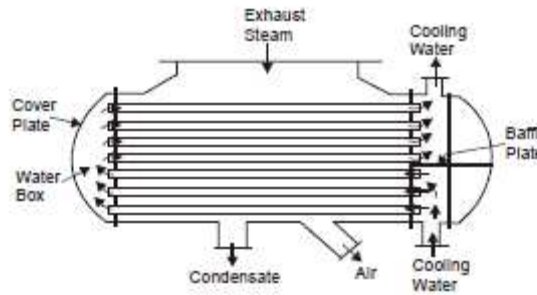

**Fig. 2**

(ii) **Central flow condenser.** Fig. 3 shows a central flow condenser. In this condenser the steam passages are all around the periphery of the shell. Air is pumped away from the centre of the condenser. The condensate moves radially towards the centre of tube nest. Some of the exhaust steams while moving towards the centre meets the undercooled condensate and pre-heats it thus reducing undercooling.

(iii) **Evaporation condenser.** In this condenser (Fig. 4) steam to be condensed is passed through a series of tubes and the cooling waterfalls over these tubes in the form of spray. A steam of air flows over the tubes to increase evaporation of cooling water, which further increases the condensation of steam.

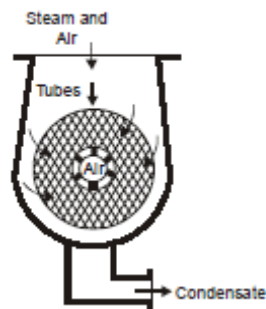

**Fig. 3**

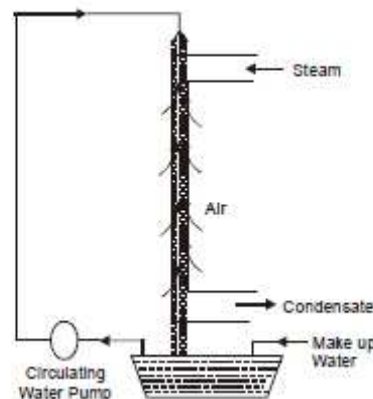

**Fig. 4**

### ADVANTAGES AND DISADVANTAGES OF A SURFACE CONDENSER

The various advantages of a surface condenser are as follows:

1. The condensate can be used as boiler feed water.
2. Cooling water of even poor quality can be used because the cooling water does not come in direct contact with steam.
3. High vacuum (about 73.5 cm of Hg) can be obtained in the surface condenser. This increases the thermal efficiency of the plant.

The various disadvantages of the surface condenser are as follows:

1. The capital cost is more.
2. The maintenance cost and running cost of this condenser is high.
3. It is bulky and requires more space.

### REQUIREMENTS OF A MODERN SURFACE CONDENSER

The requirements of ideal surface condenser used for power plants are as follows:

1. The steam entering the condenser should be evenly distributed over the whole cooling surface of the condenser vessel with minimum pressure loss.

2. The amount of cooling water being circulated in the condenser should be so regulated that the temperature of cooling water leaving the condenser is equivalent to saturation temperature of steam corresponding to steam pressure in the condenser. This will help in preventing under cooling of condensate.

3. The deposition of dirt on the outer surface of tubes should be prevented. Passing the cooling water through the tubes and allowing the steam to flow over the tubes achieve this.

4. There should be no air leakage into the condenser because presence of air destroys the vacuum in the condenser and thus reduces the work obtained per kg of steam. If there is leakage of air into the condenser air extraction pump should be used to remove air as rapidly as possible.

## JET CONDENSERS

In jet condensers the exhaust steam and cooling water come in direct contact with each other. The temperature of cooling water and the condensate is same when leaving the condensers. Elements of the jet condenser are as follows:

1. Nozzles or distributors for the condensing water.
2. Steam inlet.
3. Mixing chambers: They may be (a) parallel flow type (b) counter flow type depending on whether the steam and water move in the same direction before condensation or whether the flows are opposite.
4. Hot well.

In jet condensers the condensing water is called injection water.

## TYPES OF JET CONDENSERS

**1. Low level jet condensers (Parallel flow type).** In this condenser (Fig. 1.13) water is sprayed through jets and it mixes with steam. The air is removed at the top by an air pump. In counter flow type of condenser the cooling water flows in the downward direction and the steam to be condensed moves upward.

**2. High level or Barometric condenser.** Fig. 1.14 shows a high-level jet condenser. The condenser shell is placed at a height of 10.33 m (barometric height) above the hot well. As compared to low level jet condenser. This condenser does not flood the engine if the water extraction pump fails. A separate air pump is used to remove the air.

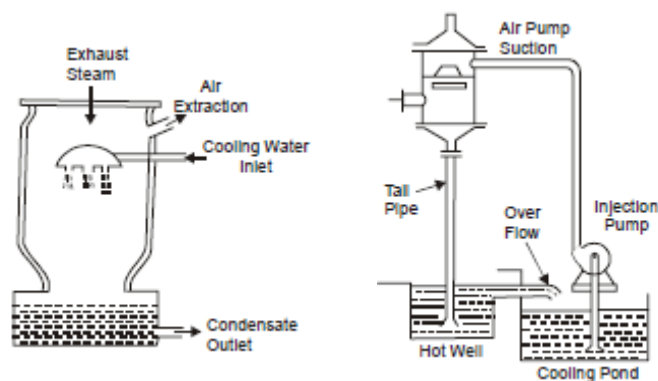

**3. Ejector Condenser.** Fig. 1.15 shows an ejector condenser. In this condenser cold water is discharged under a head of about 5 to 6 m through a series of convergent nozzles. The steam and air enter the condenser through a non-return valve. Mixing with water condenses steam. Pressure energy is partly

convert into kinetic energy at the converging cones. In the diverging come the kinetic energy is partly converted into pressure energy and a pressure higher than atmospheric pressure is achieved so as to discharge the condensate to the hot well.

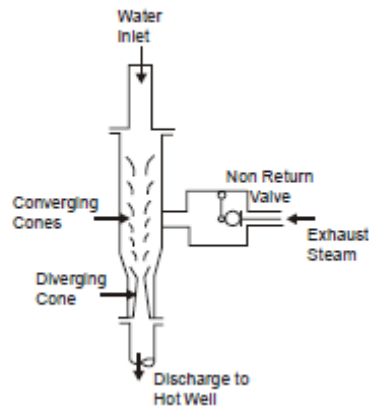

## STEAM TURBINES

Turbine is a machine wherein rotary motion is obtained by centrifugal forces, which result from a change in the direction of high velocity fluid jet that issues from a nozzle.

Water turbine is a prime mover, which uses water as the working substance to generate power. A water turbine uses the potential and kinetic energy of water and converts it into usable mechanical energy. The fluid energy is available in the natural or artificial high level water reservoirs, which are created by constructing dams at appropriate places in the flow path of rivers. When water from the reservoir is taken to the turbine, transfer of energy takes place in the blade passages of the unit. Hydraulic turbines in the form of water wheels have been used since ages; presently their application lies in the field of electric power generation. The mechanical energy made available at the turbine shaft is used to run an electric generator, which is directly coupled, to the turbine shaft. The power generated by utilizing the potential and kinetic energy of water has the advantages of high efficiency, operational flexibility, low wear tear, and ease of maintenance.

Despite the heavy capital cost involved in constructing dams and reservoirs, in running pipelines and in turbine installation (when compared to an equivalent thermal power plant) different countries have tried to tap all their waterpower resources. Appropriate types of water turbines have been installed for most efficient utilization. A number of hydro-electric power plants have and are being installed in India too to harness the available waterpower in the present crisis of fast idling energy resources. Hydroelectric power is a significant contributor to the world's energy sources.

Water (hydraulic) turbines have been broadly classified as,

1. Impulse
2. Reaction

### IMPULSE AND REACTION TURBINES

Hydraulic turbines are required to transform fluid energy into usable mechanical energy as efficiently as possible. Further depending on the site, the available fluid energy may vary in its quantum of potential and kinetic energy. Accordingly a suitable type of turbine needs to be selected to perform the required job. Based upon the basic operating principle, water turbines are categorized into impulse and reaction turbines depending on whether the pressure head available is fully or partially converted into kinetic energy in the nozzle.

**Impulse Turbine** wherein the available hydraulic energy is first converted into kinetic energy by means of an efficient nozzle. The high velocity jet issuing from the nozzle then strikes a series of suitably shaped

buckets fixed around the rim of a wheel (Fig. 1.16). The buckets change the direction of jet without changing its pressure. The resulting change in momentum sets buckets and wheel into rotary motion and thus mechanical energy is made available at the turbine shaft. The fluid jet leaves the runner with a reduced energy. An impulse turbine operates under atmospheric pressure, there is no change of static pressure across the turbine runner and the unit is often referred to as a free jet turbine. Important impulse turbines are: Pelton wheel, Turgo-impulse wheel, Girard turbine, Banki turbine and Jonval turbine etc., Pelton wheel is predominantly used at present.

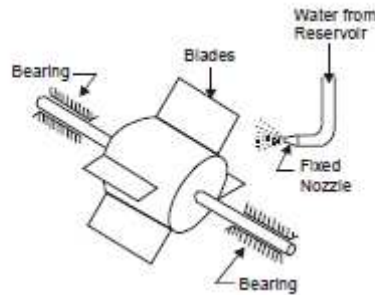

IMPULSE TURBINE

**Reaction Turbine** is one wherein a part of the total available hydraulic energy is transformed into kinetic energy before the water is taken to the turbine runner. A substantial part remains in the form of pressure energy. Subsequently, both the velocity and pressure change simultaneously as water glides along the turbine runner. The flow from inlet to outlet of the turbine is under pressure and, therefore, blades of a reaction turbine are closed passages sealed from atmospheric conditions.

Fig. illustrates the working principle of a reaction turbine in which water from the reservoir is taken to the hollow disc through a hollow shaft. The disc has four radial openings, through tubes, which are shaped as nozzles. When the water escapes through these tubes its pressure energy decreases and there is increase in kinetic energy relative to the rotating disc. The resulting reaction force sets the disc in rotation. The disc and shaft rotate in a direction opposite to the direction of water jet. Important reaction turbines are, Fourneyron, Thomson, Francis, Kaplan and Propellor turbines Francis and Kaplan turbines are widely used at present. The following table lists salient points of difference between the impulse and reaction turbines with regard to their operation and application.

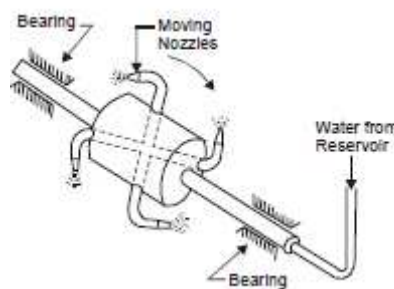

REACTION TURBINE

| Impulse Turbine   | Reaction Turbine  |
|---|---|
| 1. All the available energy of the fluid is converted into kinetic energy by an efficient nozzle that forms a free jet.                             | 1. Only a portion of the fluid energy is transformed into kinetic energy before the fluid enters the turbine runner.  |
| 2. The jet is unconfined and at atmospheric pressure throughout the action of water on the runner, and during its subsequent flow to the tail race. | 2. Water enters the runner with an excess pressure, and then both the velocity and pressure change as water passes through the runner.  |
| 3. Blades are only in action when they are in front of the nozzle.  | 3. Blades are in action all the time.   |
| 4. Water may be allowed to enter a part or whole of the wheel circumference.  | 4. Water is admitted over the circumference of the wheel.   |
| 5. The wheel does not run full and air has free access to the buckets.  | 5. Water completely fills the vane passages throughout the operation of the turbine.  |
| 6. Casing has no hydraulic function to perform; it only serves to prevent splashing and to guide the water to the tail race.                        | 6. Pressure at inlet to the turbine is much higher than the pressure at outlet; unit has to be sealed from atmospheric conditions and, therefore, casing is absolutely essential. |
| 7. Unit is installed above the tail race.   | 7. Unit is kept entirely submerged in water below the tail race.  |
| 8. Flow regulation is possible without loss.  | 8. Flow regulation is always accompanied by loss.   |
| 9. When water glides over the moving blades, its relative velocity either remains constant or reduces slightly due to friction.                     | 9. Since there is continuous drop in pressure during flow through the blade passages, the relative velocity does increase.  |

Steam turbine is one of the most important prime mover for generating electricity. This falls under the category of power producing turbo-machines. In the turbine, the energy level of the working fluid goes on decreasing along the flow stream. Single unit of steam turbine can develop power ranging from 1 mW to 1000 mW. In general, 1 mW, 2.5 mW, 5 mW, 10 mW, 30 mW, 120 mW, 210 mW, 250 mW,

350 mW, 500 mW, 660 mW, 1000 mW are in common use. The thermal efficiency of modern steam power plant above 120 mW is as high as 38% to 40%.

The purpose of turbine technology is to extract the maximum quantity of energy from the working fluid, to convert it into useful work with maximum efficiency, by means of a plant having maximum reliability, minimum cost, minimum supervision and minimum starting time. This chapter deals with the types and working of various types of steam turbine. The construction details are given in chapter 15.

## PRINCIPLE OF OPERATION OF STEAM TURBINE

The principle of operation of steam turbine is entirely different from the steam engine. In reciprocating steam engine, the pressure energy of steam is used to overcome external resistance and the dynamic action of steam is negligibly small. But the steam turbine depends completely upon the dynamic action of the steam. According to Newton's Second Law of Motion, the force is proportional to the rate of change of momentum (mass  $\times$  velocity). If the rate of change of momentum is caused in the steam by allowing a high velocity jet of steam to pass over curved blade, the steam will impart a force to the blade. If the blade is free, it will move off (rotate) in the direction of force. In other words, the motive power in a steam turbine is obtained by the rate of change in moment of momentum of a high velocity jet of steam impinging on a curved blade which is free to rotate. The steam from the boiler is expanded in a passage or nozzle where due to fall in pressure of steam, thermal energy of steam is converted into kinetic energy of steam, resulting in the emission of a high velocity jet of steam which, Principle of working impinges on the moving vanes or blades of turbine (Fig. 6.1).

Attached on a rotor which is mounted on a shaft supported on bearings, and here steam undergoes a change in direction of motion due to curvature of blades which gives rise to a change in momentum and therefore a force. This constitutes the driving force of the turbine. This arrangement is shown.

It should be realized that the blade obtains no motive force from the static pressure of the steam or from any impact of the jet, because the blade is designed such that the steam jet will glide on and off the blade without any tendency to strike it.

As shown in Fig. 6.2, when the blade is locked the jet enters and leaves with equal velocity, and thus develops maximum force if we neglect friction in the blades. Since the blade velocity is zero, no mechanical work is done. As the blade is allowed to speed up, the leaving velocity of jet from the blade



reduces, which reduces the force. Due to blade velocity the work will be done and maximum work is done when the blade speed is just half of the steam speed. In this case, the steam velocity from the blade is near about zero *i.e.* it is trail of inert steam since all the kinetic energy of steam is converted into work. The force and work done become zero when the blade speed is equal to the steam speed. From the above discussion, it follows that a steam turbine should have a row of nozzles, a row of moving blades fixed to the rotor, and the casing (cylinder). A row of *nozzles and a row of moving blades constitutes a stage of turbine.*

## CLASSIFICATION OF STEAM TURBINE

Steam turbine may be classified as follows: -

(A) On the Basis of Principle of Operation :

(i) Impulse turbine

(a) Simple, (b) Velocity stage, (c) Pressure stage, (d) combination of (b) and (c).

STEAM TURBINE 197

(ii) Impulse-reaction turbine

(a) 50% (Parson's) reaction, (b) Combination of impulse and reaction.

(i) **Impulse Turbine:** If the flow of steam through the nozzles and moving blades of a turbine takes place in such a manner that the steam is expanded only in nozzles and pressure at the outlet sides of the blades is equal to that at inlet side; such a turbine is termed as impulse turbine because it works on the principle of impulse. In other words, in impulse turbine, the drop in pressure of steam takes place only in nozzles and not in moving blades. This is obtained by making the blade passage of constant cross-section area

As a general statement it may be stated that energy transformation takes place only in nozzles and moving blades (rotor) only cause energy transfer. Since the rotor blade passages do not cause any acceleration

of fluid, hence chances of flow separation are greater which results in lower stage efficiency.

(ii) **Impulse-Reaction Turbine:** In this turbine, the drop in pressure of steam takes place in *fixed (nozzles) as well as moving blades*. The pressure drop suffered by steam while passing through the moving blades causes a further generation of kinetic energy within the moving blades, giving rise to reaction and adds to the propelling force which is applied through the rotor to the turbine shaft. Since this turbine works on the principle of impulse and reaction both, so it is called impulse-reaction turbine. This is achieved by making the blade passage of varying cross-sectional area (*converging type*).

In general, it may be stated that energy transformation occurs in both fixed and moving blades.

The rotor blades cause both energy transfer and transformation. Since there is an acceleration of flow in moving blade passage hence chances of separation of flow is less which results in higher stage efficiency.

(B) On the basis of "Direction of Flow" :

(i) Axial flow turbine, (ii) Radial flow turbine, (iii) Tangential flow turbine.

(i) **Axial Flow Turbine.** In axial flow turbine, the steam flows along the axis of the shaft. It is the most suitable turbine for large turbo-generators and that is why it is used in all modern steam power plants.

(ii) **Radial Flow Turbine.** In this turbine, the steam flows in the radial direction. It incorporates two shafts end to end, each driving a separate generator. A disc is fixed to each shaft. Rings of 50% reaction radial-flow bladings are fixed to each disk. The two sets of bladings rotate counter to each other. In this way, a relative speed of twice the running speed is achieved and every blade row is made to work. The final stages may be of axial flow design in order to achieve a larger area of flow. Since this type of turbine can be warmed and started quickly, so it is very suitable for use at times of peak load. Though this type of turbine is very successful in the smaller sizes but formidable design difficulties have hindered the development of large turbines of this type. In Sweden, however, composite radial/axial flow turbines have been built of outputs upto 275 MW. Sometimes, this type of turbine is also known as Liungstrom turbine after the name of its inventor B and F. Liungstrom of Sweden .

(iii) **Tangential Flow Turbine.** In this type, the steam flows in the tangential direction. This turbine is very robust but not particularly efficient machine, sometimes used for driving power station auxiliaries. In this turbine, nozzle directs steam tangentially into buckets milled in the periphery of a single wheel, and on exit the steam turns through a reversing chamber, reentering bucket further round the periphery. This process is repeated

several times, the steam flowing a helical path. Several nozzles with reversing chambers may be used



around the wheel periphery.

(C) On the Basis of Means of Heat Supply:

- (i) Single pressure turbine,
- (ii) Mixed or dual pressure turbine
- (iii) Reheated turbine.
- (a) Single (b) Double

(i) **Single Pressure Turbine** : In this type of turbine, there is single source of steam supply.

(ii) **Mixed or Dual Pressure Turbine** : This type of turbines, use two sources of steam, at different pressures. The dual pressure turbine is found in nuclear power stations where it uses both sources continuously. The mixed pressure turbine is found in industrial plants (*e.g.*, rolling mill, colliery, etc.) where there are two supplies of steam and use of one supply is more economical than the other; for example, the economical steam may be the exhaust steam from engine which can be utilised in the L. P. stages of steam turbine. Dual pressure system is also used in combined cycle.

(iii) **Reheated Turbine** : During its passage through the turbine steam may be taken out to be reheated in a reheater incorporated in the boiler and returned at higher temperature to be expanded in (Fig. 6.6). This is done to avoid erosion and corrosion problems in the bladings and to improve the power output and efficiency. The reheating may be single or double or triple.

(D) On the Basis of Means of Heat Rejection :

(i) Pass-out or extraction turbine, (ii) Regenerative turbine, (iii) Condensing turbine, (iv) Noncondensing turbine, (v) Back pressure or topping turbine.

(i) **Pass-out Turbine**. In this turbine, (Fig. 6.4), a considerable proportion of the steam is extracted from some suitable point in the turbine where the pressure is sufficient for use in process heating; the remainder continuing through the turbine. The latter is controlled by separate valve-gear to meet the

STEAM TURBINE 199

difference between the pass-out steam and electrical load requirements. This type of turbine is suitable where there is dual demand of steam—one for power and the other for industrial heating, for example sugar industries. Double pass-out turbines are sometimes used.

(ii) **Regenerative Turbine**. This turbine incorporates a number of extraction branches, through which small proportions of the steam are continuously extracted for the purpose of heating the boiler feed water in a feed heater in order to increase the thermal efficiency of the plant. Now a days, all steam power plants are equipped with reheating and regenerative arrangement.

(iii) **Condensing Turbine**. In this turbine, the exhaust steam is condensed in a condenser and the condensate is used as feed water in the boiler. By this way the condensing turbine allows the steam to expand to the lowest possible pressure before being condensed. All steam power plants use this type of turbine.

(iv) **Non-Condensing Turbine**. When the exhaust steam coming out from the turbine is not condensed but exhausted in the atmosphere is called non-condensing turbine. The exhaust steam is not recovered for feed water in the boiler.

(v) **Back Pressure or Topping Turbine**. This type of turbine rejects the steam after expansion to the lowest suitable possible pressure at which it is used for heating purpose. Thus back pressure turbine supplies power as well as heat energy.

The back pressure turbine generally used in sugar industries provides low pressure steam for heating apparatus, where as a topping turbine exhausts into a turbine designed for lower steam conditions.

(E) On the Basis of Number of Cylinder: Turbine may be classified as

(i) Single cylinder and (ii) Multi-cylinder.

(i) **Single Cylinder**. When all stages of turbine are housed in one casing, then it is called single cylinder. Such a single cylinder turbine uses one shaft.

(ii) **Multi-Cylinder**. In large output turbine, the number of the stages needed becomes so high that additional bearings are required to support the shaft. Under this circumstances, multi-cylinders are used.

(F) On the Basis of Arrangement of Cylinder Based on General Flow of Steam. (i) Single flow,

(ii) Double flow, and (iii) Reversed flow

**Single Flow**. In a single flow turbines, the steam enters at one end, flows once [Fig. 6.5(a)] through

Single flow

(a) (b) (c)

Double flow Reversed flow

**Fig. 6.5**

the bladings in a direction approximately parallel to this axis, emerges at the other end. High pressure

cylinder uses single flow. This is also common in small turbines.

**Double Flow.** In this type of turbines, the steam enters at the centre and divides, the two portions passing axially away from other through separate sets of blading on the same rotor Fig. The low pressure cylinder normally uses double flow). This type of unit is completely balanced against the end thrust and gives large area of flow through two sets of bladings. This also helps in reducing the blade height as mass flow rate becomes half as compared to single flow for the same conditions.

**Reversed Flow.** Reversed flow arrangement is sometimes used in h.p. cylinder where higher temperature steam is used on the larger sets in order to minimise differential expansion *i.e.* unequal expansion of rotor and casing. The use of single, double and reversed flow is shown in the layout Fig. 6.5(c).

(G) On the Basis of Number of Shaft

(i) Tandem compound, (ii) Cross compound

(i) **Tandem Compound.** Most multi-cylinder turbines drive a single shaft and single generator Such turbines are termed as tandem compound turbines.

(ii) **Cross Compound.** In this type, two shafts are used driving separate generator. The may be one of turbine house arrangement, limited generator size, or a desire to run shafting at half speed. The latter choice is sometimes preferred so that for the same centrifugal stress, longer blades may be used, giving a larger leaving area, a smaller velocity and hence a small leaving loss.

(H) On the Basis of Rotational Speed

(i) constant speed turbines

(ii) Variable speed turbines

(i) **Constant Speed Turbines.** Requirements of rotational speed are extremely rigid in turbines which are directly connected to electric generators as these must be a-c unit except in the smallest sizes and must therefore run at speeds corresponding to the standard number of cycles per second and governed by the following equation :

$$N = 120 \times \text{Number of cycles per second} = 120 f/p$$

Number of poles

The minimum number of poles, in a generator is two and correspondingly the maximum possible speed for 60 cycle is 3,600 rpm; for 50 c/s of frequency, the speeds would be 3,000, 1500 and 750 rpm for 2, 4 and 8 poles machines respectively.

(ii) **Variable Speed Turbines.** These turbines have geared units and may have practically any speed ratio between the turbine and the driven machine so that the turbine may be designed for its own most efficient speed. Such turbines are used to drive ships, compressors, blowers and variable frequency generators.

## THE SIMPLE IMPULSE TURBINE

This type of turbine works on the principle of impulse and is shown diagrammatically. It mainly consists of a nozzle or a set of nozzles, a rotor mounted on a shaft, one set of moving blades attached to the rotor and a casing. The uppermost portion of the diagram shows a longitudinal section through the upper half of the turbine, the middle portion shows the development of the nozzles and blading *i.e.* the actual shape of the nozzle and blading, and the bottom portion shows the variation of absolute velocity and absolute pressure during flow of steam through passage of nozzles and blades. The example of this type of turbine is the de-Laval Turbine.

It is obvious from the figure that the complete expansion of steam from the steam chest pressure to the exhaust pressure or condenser pressure takes place only in one set of nozzles *i.e.* the pressure drop takes place only in nozzles. It is assumed that the pressure in the recess between nozzles and blades

STEAM TURBINE 201

remains the same. The steam at condenser pressure or exhaust pressure enters the blade and comes out at the same pressure *i.e.* the pressure of steam in the blade passages remains approximately constant and equal to the condenser pressure. Generally, converging-diverging nozzles are used. Due to the relatively large ratio of expansion of steam in the nozzles, the steam leaves the nozzles at a very high velocity (supersonic), of about 1100 m/s. It is assumed that the velocity remains constant in the recess between the nozzles and the blades. The steam at such a high velocity enters the blades and reduces along the passage of blades and comes out with an appreciable amount of velocity (Fig. 6.6).

As it has been already shown, that for the good economy or maximum work, the blade speed should be one half of the steam speed so blade velocity is of about 500 m/s which is very high. This results in a very high rotational speed, reaching 30,000 r.p.m. Such high rotational speeds can only be

utilised to drive generators or machines with large reduction gearing arrangements.

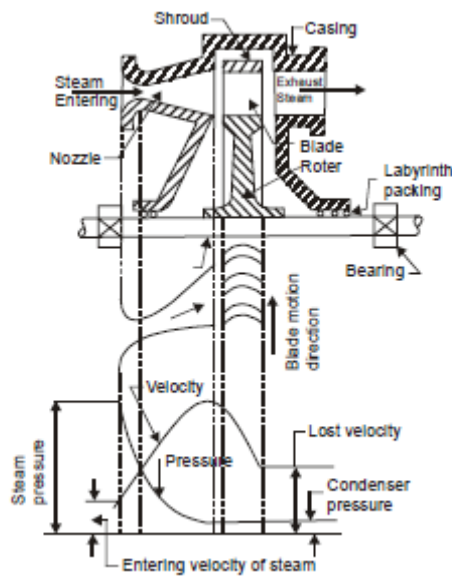

Impulse Turbine.

In this turbine, the leaving velocity of steam is also quite appreciable resulting in an energy loss, called “carry over loss” or “leaving velocity loss”. This leaving loss is so high that it may amount to about 11 percent of the initial kinetic energy. This type of turbine is generally employed where relatively small power is needed and where the rotor diameter is kept fairly small.

### COMPOUNDING OF IMPULSE TURBINE

Compounding is a method for reducing the rotational speed of the impulse turbine to practical limits. As we have seen, if the high velocity of steam is allowed to flow through one row of moving blades, it produces a rotor speed of about 30,000 r.p.m. which is too high for practical use. Not only this, the leaving loss is also very high. It is therefore essential to incorporate some improvements in the simple impulse turbine for practical use and also to achieve high performance. This is possible by making use of more than one set of nozzles, blades, rotors, in a series, keyed to a common shaft, so that either the steam pressure or the jet velocity is absorbed by the turbine in stages. The leaving loss also will then be less. This process is called compounding of steam turbines. There are three main types

- (a) Pressure-compounded impulse turbine.
- (b) Velocity-compounded impulse turbine.
- (c) Pressure and velocity compounded impulse turbine.

### PRESSURE COMPOUNDED IMPULSE TURBINE

In this type of turbine, the compounding is done for pressure of steam only *i.e.* to reduce the high rotational speed of turbine the whole expansion of steam is arranged in a number of steps by employing a number of simple turbine in a series keyed on the same shaft as shown. Each of these simple impulse turbine consisting of one set of nozzles and one row of moving blades is known as a stage of the turbine and thus this turbine consists of several stages. The exhaust from each row of moving blades enters the succeeding set of nozzles. Thus we can say that this arrangement is nothing but splitting up the whole pressure drop.

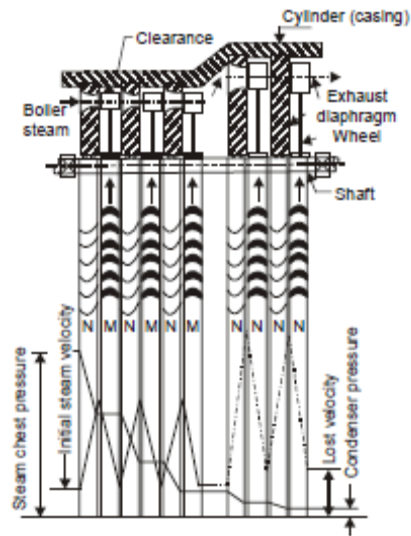

**Fig.** Pressure Compounded Impulse Turbine.

from the steam chest pressure to the condenser pressure into a series of smaller pressure drop across several stages of impulse turbine and hence this turbine is called, pressure-compound impulse turbine. The pressure and velocity variation are also shown. The nozzles are fitted into a diaphragm which is locked in the casing. This diaphragm separates one wheel chamber from another. All rotors are mounted on the same shaft and the blades are attached on the rotor. The rotor (*i.e.* disc) may be keyed to the shaft or it may be integral part of shaft.

The expansion of steam only takes place in the nozzles while pressure remains constant in the moving blades because each stage is a simple impulse turbine. So it is obvious from the pressure curve that the space between any two consecutive diaphragms is filled with steam at constant pressure and the pressure on either side of the diaphragm is different. Since the diaphragm is a stationary part, there must be clearance between the rotating shaft and the diaphragm. The steam tends to leak through this clearance for which devices like labyrinth packings, etc. are used.

Since the drop in pressure of steam per stage is reduced, so the steam velocity leaving the nozzles and entering the moving blades is reduced which reduces the blade velocity. Hence for good economy or maximum work shaft speed is significantly reduced so as to be reduced by increasing the number of stages according to one's need. The leaving velocity of the last stage of the turbine is much less compared to the de Laval turbine and the leaving loss amounts to about 1 to 2 percent of the initial total available energy. This turbine was invented by the late prof L. Rateau and so it is also known as Rateau Turbine.

### **SIMPLE VELOCITY-COMPOUNDED IMPULSE TURBINE**

In this type of turbine, the compounding is done for velocity of steam only *i.e.* drop in velocity is arranged in many small drops through many moving rows of blades instead of a single row of moving blades. It consists of a nozzle or a set of nozzles and rows of moving blades attached to the rotor or wheel and rows of fixed blades attached to casing as shown in Fig. 6.8.

The fixed blades are guide blades which guide the steam to succeeding rows of moving blades, suitably arranged between the moving blades and set in a reversed manner. In this turbine, three rows or rings of moving blades are fixed on a single wheel or rotor and this type of wheel is termed as the three row wheel. There are two blades or fixed blades placed between the first and the second and the second and third rows of moving blades respectively.

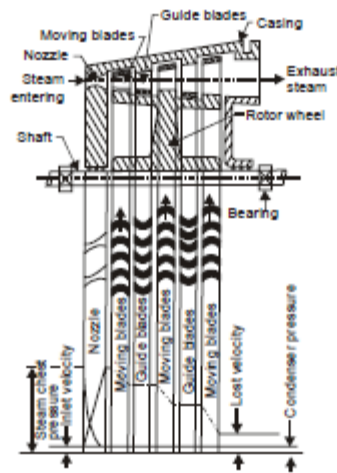

Fig. Velocity Compounded Impulse Turbine.

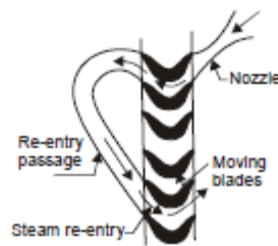

Fig. Flow of Steam on Blades.

The whole expansion of steam from the steam chest pressure to the exhaust pressure takes place in the nozzles only. There is no drop in either in the moving blades or the fixed *i.e.* the pressure remains constant in the blades as in the simple impulse turbine. The steam velocity from the exit of the nozzle is very high as in the simple impulse turbine. Steam with this high velocity enters the first row of moving blades and on passing through these blades, the Velocity slightly reduces *i.e.* the steam gives up a part of its kinetic energy and reissues from this row of blades with a fairly high velocity. It then enters the first row of guide blades which directs the steam to the second row of moving blades. Actually, there is a slight drop in velocity in the fixed or guide blades due to friction. On passing through the second row of moving blades some drop in velocity again occurs *i.e.* steam gives up another portion of its kinetic energy to the rotor. After this, it is redirected again by the second row of guide lades to the third row of moving blades where again some drop in velocity occurs and finally the steam leaves the wheel with a certain velocity in a more or less axial direction. compared to the simple impulse turbine, the leaving velocity is small and it is about 2 percent of initial total available energy of steam. So we can say that this arrangement is nothing but splitting up the velocity gained from the exit of the nozzles into many drops through several rows of moving blades and hence the name velocity compounded This type of turbine is also termed as Curtis turbine. Due to its low efficiency the three row wheel is used for driving small machines The two row wheel is more efficient than the three-row wheel. velocity compounding is also possible with only one row of moving blades. The whole pressure drop takes place in the nozzles and the high velocity steam passes through the moving blades into a reversing chamber where the direction of the steam is changed and the same steam is arranged to pass through the moving blade of the same rotor. So instead of using two or three rows of moving blades, only one row is required to pass the steam again and again; thus in each pass velocity decreases.

## PRESSURE AND VELOCITY COMPOUNDED IMPULSE TURBINE

This type of turbine is a combination of pressure and velocity compounding and is diagrammatically. There are two wheels or rotors and on each, only two rows of moving blades are attached cause two-row wheel are more efficient than three-row wheel. In each wheel or rotor, velocity drops *i.e.* drop in velocity is achieved by many rows of moving blades hence it is velocity compounded. There are two sets of nozzles in which whole pressure drop takes place *i.e.* whole pressure drop has been divided in small drops, hence it is pressure-compounded.

In the first set of nozzles, there is some decrease in pressure which gives some kinetic energy to the steam and there is no drop in pressure in the two rows of moving blades of the first wheel and in the first row of fixed blades. Only, there is a velocity drop in moving blades though there is also a slight drop in velocity due to friction in the fixed blades. In second set of nozzles, the remaining pressure drop takes place but the velocity here increases and the drop in velocity takes place in the moving blades of the second wheel or rotor. Compared to the pressure-compounded impulse turbine this arrangement was more popular due to its simple construction. It is, however, very rarely used now due to its low efficiency.

## IMPULSE-REACTION TURBINE

As the name implies this type of turbine utilizes the principle of impulse and reaction both. Such a type of turbine is diagrammatically shown. There are a number of rows of moving blades attached to the rotor and an equal number of fixed blades attached to the casing.

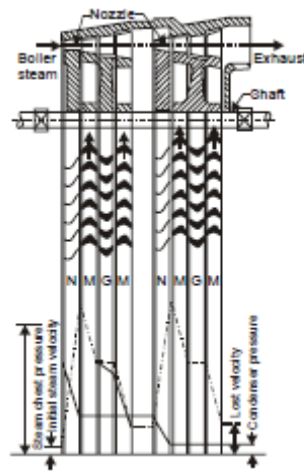

Fig. Impulse Reaction Turbine.

In this type of turbine, the fixed blades which are set in a reversed manner compared to the moving blades, corresponds to nozzles mentioned in connection with the impulse turbine. Due to the row of fixed blades at the entrance, instead of the nozzles, steam is admitted for the whole circumference and hence there is all-round or complete admission. In passing through the first row of fixed blades, the steam undergoes a small drop in pressure and hence its velocity somewhat increases. After this it then enters the first row of moving blades and just as in the impulse turbine, it suffers a change in direction and therefore in momentum. This momentum gives rise to an impulse on the blades.

But in this type of turbine, the passage of the moving blades is so designed (converging) that there is a small drop in pressure of steam in the moving blades which results in a increase in kinetic energy of steam. This kinetic energy gives rise to reaction in the direction opposite to that of added velocity. Thus, the gross propelling force or driving force is the vector sum of impulse and reaction forces. Commonly, this type of turbine is called Reaction Turbine. It is obvious from the Fig. that there is a gradual drop in pressure in both moving blades and fixed blades.

As the pressure falls, the specific volume increases and hence in practice, the height of blades is increased in steps *i.e.* say upto 4 stages it remains constant, then it increases and remains constant for the next two stages.

In this type of turbine, the steam velocities are comparatively moderate and its maximum value is about equal to blade velocity. In general practice, to reduce the number of stages, the steam velocity is arranged greater than the blade velocity. In this case the leaving loss is about 1 So 2 per cent of the total initial available energy. This type of turbine is used mostly in all power plants where it is great success.

An example of this type of turbine is the Parsons-Reaction Turbine. The power plants 30 MW and above are all impulse-reaction type.



## ADVANTAGES OF STEAM TURBINE OVER STEAM ENGINE

The various advantages of steam turbine are as follows :

- (i) It requires less space.
- (ii) Absence of various links such as piston, piston rod, cross head etc. make the mechanism simple. It is quiet and smooth in operation,
- (iii) Its over-load capacity is large.
- (iv) It can be designed for much greater capacities as compared to steam engine. Steam turbines can be built in sizes ranging from a few horse power to over 200,000 horse power in single units.
- (v) The internal lubrication is not required in steam turbine. This reduces to the cost of lubrication.
- (vi) In steam turbine the steam consumption does not increase with increase in years of service.
- (vii) In steam turbine power is generated at uniform rate, therefore, flywheel is not needed.
- (viii) It can be designed for much higher speed and greater range of speed.
- (ix) The thermodynamic efficiency of steam turbine is higher.

## STEAM TURBINE CAPACITY

The capacities of small turbines and coupled generators vary from 500 to 7500 kW whereas large turbo alternators have capacity varying from 10 to 90 mW. Very large size units have capacities up to 500 mW.

Generating units of 200 mW capacity are becoming quite common. The steam consumption by steam turbines depends upon steam pressure, and temperature at the inlet, exhaust pressure number of bleeding stages etc. The steam consumption of large steam turbines is about 3.5 to 5 kg per kWh.

$\text{Turbine kW} = \text{Generator kW} / \text{Generator efficiency}$

Generators of larger size should be used because of the following reasons:

- (i) Higher efficiency.
- (ii) Lower cost per unit capacity.
- (iii) Lower space requirement per unit capacity.

3.45.1 Nominal rating.  
It is the declared power capacity of turbine expected to be maximum load.

## CAPABILITY

The capability of steam turbine is the maximum continuous out put for a clean turbine operating under specified throttle and exhaust conditions with full extraction at any openings if provided. The difference between capability and rating is considered to be overload capacity. A common practice is to design a turbine for capability of 125% nominal rating and to provide a generator that will absorb rated power at 0.8 power factor. By raising power factor to unity the generator will absorb the full turbine capability.

## STEAM TURBINE GOVERNING

Governing of steam turbine means to regulate the supply of steam to the turbine in order to maintain speed of rotation sensibly constant under varying load conditions. Some of the methods employed are as follows :

- (i) Bypass governing. (ii) Nozzle control governing. (iii) Throttle governing.

In this system the steam enters the turbine chest (C) through a valve (V) controlled by governor.

In case of loads of greater than economic load a bypass valve (V<sub>1</sub>) opens and allows steam to pass from the first stage nozzle box into the steam belt (S).

In this method of governing the supply of steam of various nozzle groups N<sub>1</sub>, N<sub>2</sub>, and N<sub>3</sub> is regulated by means of valves V<sub>1</sub>, V<sub>2</sub> and V<sub>3</sub> respectively.

In this method of governing the double beat valve is used to regulate the *flow* of steam into the turbine. When the load on the turbine decreases, its speed will try to increase. This will cause the *fly* bar to move outward which will in return operate the lever arm and thus the double beat valve will get moved to control the supply of steam to turbine. In this case the valve will get so adjusted that less amount of steam flows to turbine.

## STEAM TURBINE PERFORMANCE

Turbine performance can be expressed by the following factors :

- (i) The steam *flow* process through the unit-expansion line or condition curve.
- (ii) The steam *flow* rate through the unit.
- (iii) Thermal efficiency.
- (iv) Losses such as exhaust, mechanical, generator, radiation etc.

Mechanical losses include bearing losses, oil pump losses and generator bearing losses. Generator losses include will electrical and mechanical losses. Exhaust losses include the kinetic energy of the steam as it leaves the last stage and the pressure drop from the exit of last stage to the condenser stage. For successful operation of a steam turbine it is desirable to supply steam at constant pressure and temperature. Steam pressure can be easily regulated by means of safety valve fitted on the boiler.

The steam temperature may try to fluctuate because of the following reasons :

- (i) Variation in heat produced due to varying amounts of fuel burnt according to changing loads.
- (ii) Fluctuation in quantity of excess air.
- (iii) Variation in moisture content and temperature of air entering the furnace.

208 POWER PLANT ENGINEERING

- (iv) Variation in temperature of feed water.
- (v) The varying condition of cleanliness of heat absorbing surface.

The efficiency of steam turbines can be increased:

- (i) By using super heated steam.
- (ii) Use of bled steam reduces the heat rejected to the condenser and this increases the turbine efficiency.

## STEAM TURBINE TESTING

Steam turbine tests are made for the following:

- (i) Power
- (ii) Valve setting
- (iii) Speed regulation
- (iv) Over speed trip setting
- (v) Running balance.

Steam condition is determined by pressure gauge, and thermometer where steam is super heated.

The acceptance test as ordinarily performed is a check on (a) Output, (b) Steam rate or heat consumption, (c) Speed regulation, (d) Over speed trip setting.

Periodic checks for thermal efficiency and load carrying ability are made. Steam used should be clean. Unclean steam represented by dust carry over from super heater may cause a slow loss of load carrying ability.

Thermal efficiency of steam turbine depends on the following factors:

- (i) Steam pressure and temperature at throttle valve of turbine.
- (ii) Exhaust steam pressure and temperature.
- (iii) Number of bleedings.

Lubricating oil should be changed or cleaned after 4 to 6 months.

## CHOICE OF STEAM TURBINE

The choice of steam turbine depends on the following factors :

- (i) Capacity of plant
- (ii) Plant load factor and capacity factor
- (iii) Thermal efficiency
- (iv) Reliability
- (v) Location of plant with reference to availability of water for condensate.

## STEAM TURBINE GENERATORS

A generator converts the mechanical shaft energy it receive from the turbine into electrical energy.

Steam turbine driven a.c. synchronous generators (alternators) are of two or four pole designs.

These are three phase measuring machines offering economic, advantages in generation and transmission.

Generator losses appearing as heat must be constantly removed to avoid damaging the windings.

Large generators have cylindrical rotors with minimum of heat dissipation surface and so they have forced ventilation to remove the heat. Large generators generally use an enclosed system with air or hydrogen coolant. The gas picks up the heat from the generator any gives it up to the circulating water in

the heat exchanger.

## STEAM TURBINE SPECIFICATIONS

Steam turbine specifications consist of the following:

- (i) Turbine rating. It includes :
  - (a) Turbine kilowatts
  - (b) Generator kilovolt amperes
  - (c) Generator Voltage
  - (d) Phases
  - (e) Frequency
  - (f) Power factor
  - (g) Excitor characteristics.
- (ii) Steam conditions. It includes the following:
  - (a) Initial steam pressure, and Temperature
  - (b) Reheat pressure and temperature
  - (c) Exhaust pressure.
- (iii) Steam extraction arrangement such as automatic or non-automatic extraction.
- (iv) Accessories such as stop and throttle valve, tachometer etc.
- (v) Governing arrangement.

## SOLVED EXAMPLES PROBLEMS

**Example 1.** Steam at a pressure of 15 kg/cm<sup>2</sup> (abs) and temperature of 250°C. is expanded through a turbine to a pressure of 5 kg/cm<sup>2</sup> (abs.). It is then reheated at constant pressure to a temperature of 200°C after which it completes its expansion through the turbine to an exhaust pressure of 0.1 kg/cm<sup>2</sup>(abs). Calculate theoretical efficiency.

- (a) Taking reheating into account
- (b) If the steam was expanded direct to exhaust pressure without reheating

**Solution.** From Mollier diagram

H<sub>1</sub> = Total heat of steam at 15 kg/cm<sup>2</sup> and 250°C = 698 Kcal/kg

H<sub>2</sub> = Total heat of steam at 5 kg/cm<sup>2</sup> = 646 Kcal/kg

Now steam is reheated to 200°C at constant pressure

H<sub>3</sub> = Heat in this stage = 682 Kcal/kg

This steam is expanded to 0.1 kg/cm<sup>2</sup>

H<sub>4</sub> = Heat in this stage = 553 Kcal/kg

H<sub>w4</sub> = Total Heat of water at 0.1 kg/cm<sup>2</sup> = 45.4 Kcal/kg

$$\text{Theoretical efficiency} = \frac{(H_1 - H_2) + (H_3 - H_4)}{\{H_1 + (H_3 - H_2) - H_{w4}\}} = \frac{(698 - 646) + (682 - 533)}{\{698 + (642 - 646) - 45.4\}}$$

$$= 0.293 \text{ or } 29.3\% \text{ Ans.}$$

**Example 2.** Determine the thermal efficiency of the basic cycle of a steam power plant (Rankine Cycle), the specific and hourly steam consumption for a 50 mW steam turbine operating at inlet conditions:

Pressure 90 bar and temperature 500°C. The condenser pressure is 0.40 bar

**Solution.** From Mollier diagram

H<sub>1</sub> = Total heat of steam at point 1 = 3386.24 kJ/kg

H<sub>2</sub> = Total heat of steam at point 2 = 2006.2 kJ/kg

$H_{w2}$  = Total Heat of water at point 2 = 121.42 kJ/kg

$$\begin{aligned} \text{(a) Thermal efficiency} &= \frac{(H_1 - H_2)}{(H_1 - H_{w2})} \\ &= \frac{(3386.24 - 2006.2)}{(3386.24 - 121.42)} = 42.27\% \end{aligned}$$

(b) Specific steam consumption is the amount of steam in kg per kW-hr.

Now 1 kW-hr = 3600 kJ

$$\begin{aligned} \text{Specific steam consumption} &= \frac{3600}{(H_1 - H_2)} = \frac{3600}{(3386.24 - 2006.2)} \\ &= 2.61 \text{ kg/kW-hr} \end{aligned}$$

$$\begin{aligned} \text{(c) Hourly steam consumption} &= 2.61 \times \text{Kilowatts} \\ &= 2.61 \times 50,000 = 1.305 \text{ Tonnes/hr Ans.} \end{aligned}$$

**Example 3.** A steam power plant, operating with one regenerative feed water heating is run at the initial steam conditions of 35.0 bar and 440°C with exhaust pressure of 0.040 bar. Steam is bled from the turbine for feed water heating at a pressure of 1.226 bar. Determine

- (1) Specific heat consumption
- (2) Thermal efficiency of the cycle
- (3) Economy percentage compared with the cycle of a simple condensing power plant.

**Solution.** From Mollier diagrams and steam table,

$$H_1 = 3314 \text{ kJ/kg}$$

$$H_2 = 2560 \text{ kJ/kg}$$

$$H_3 = 2100 \text{ kJ/kg}$$

$$H_{w2} = 439.43 \text{ kJ/kg}$$

$$H_{w3} = 121.42 \text{ kJ/kg}$$

From the heat balance for the feed water heater

$$m(H_2 - H_{w2}) = (1 - m)(H_{w2} - H_{w3})$$

$$m(2560 - 439.43) = (1 - m)(439.43 - 121.42)$$

On solving, we get  $m = 0.1304 \text{ kg}$

$$\begin{aligned}\text{Total work done} &= 1 \times (H_1 - H_2) + (1 - m)(H_2 - H_3) \\ &= (3314 - 2460) + (1 - 0.1304)(2560 - 2100) \\ &= 1154 \text{ kJ/kg}\end{aligned}$$

(1) Specific steam consumption =  $\frac{3600}{1154} = 3.12 \text{ Kg/kW-hr. Ans.}$

(2) Thermal efficiency =  $\frac{1154}{(3314 - 439.43)} = 40.15\% \text{ Ans.}$

(3) With out regeneration feed water heating the work done will be  
 $H_1 - H_2 = 3314 - 2100 = 1214 \text{ kJ/kg}$

$$\text{Steam consumption} = \frac{3600}{1214} = 2.94 \text{ kg/kW-hr}$$

Without regeneration heating, the thermal efficiency

$$\eta = \frac{(H_1 - H_3)}{(H_1 - H_{u3})}$$

Now from the steam tables

$$H_{u3} = 121.42 \text{ kJ/kg}$$

$$\eta = \frac{(3314 - 2100)}{(3314 - 121.42)} = 0.38$$

Increase in thermal efficiency due to regeneration feed water heating is

$$= \frac{(0.4015 - 0.38)}{0.4015} = 5.5 \% \text{ Ans.}$$

Now,  $V_b = 144 \text{ m/s}$ ;  $V_1 = 144 \times 0.48 = 300 \text{ m/s}$   
 $V^2/2 \times 10^3 = \text{Isentropic heat drop} \times \text{Nozzle efficiency}$

(1)  $\text{Isentropic heat drop} = \frac{300^2}{(2 \times 10^3 \times 0.92)} = 48.9 \text{ kJ/kg}$

(2)  $\text{Energy lost in nozzles} = \text{Isentropic heat drop} \times (1 - \eta^n) = 48.9 \times (1 - 0.92) = 3.91 \text{ kJ/kg}$

$\text{Energy lost in moving blades due to friction} = \frac{V_{r1} - V_{r2}^2}{(2 \times 10^3)} \text{ kJ/kg}$

Now  $V_{r0} = 0.97 \times V_{r1}$

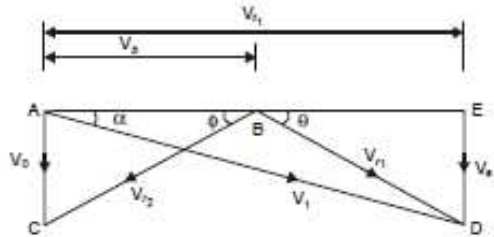

To draw velocity triangles,  $AB = V_b = 144 \text{ m/s}$ ,  $\alpha = 15^\circ$ ,  $V_1 = 300 \text{ m/s}$  With this triangle ABD can be completed.

Measure  $V_{r1}$ , and  $\theta$ ,  $V_{r1} = 168 \text{ m/s}$ ,  $\theta = 29^\circ$

$V_{r0} = 0.97 \times 168 = 163 \text{ m/s}$ , and  $\theta = 29^\circ$ .

Velocity triangle ABC can be completed

$\text{Energy lost in moving blades due to friction} = \frac{168^2 - 163^2}{(2 \times 10^3)} = 0.83 \text{ kJ/kg } 2 \times 10^3$

(3)  $\text{Energy lost due to finite velocity of steam leaving the stage} = \frac{V_0^2}{(2 \times 10^3)}$

From velocity triangle,  $V_0 = 80 \text{ m/s}$

$\text{Energy lost} = \frac{80^2}{(2 \times 10^3)}$

(4)  $V_b = \pi D n / 60$

$144 = \pi \times D \times \frac{3000}{60}$

$D = 0.917 \text{ m}$



$$\text{Area of flow, } A = \pi D h = 3.14 \times 0.917 \times \frac{10}{100} = 0.288 \text{ m}^2$$

Now from steam table, for steam dry and saturated at 9.8 bar,

$$V_s = 0.98 \text{ m}^3/\text{kg}$$

$V_{a1} = 77.65 \text{ m/s}$  from velocity triangles

$$\text{Mass flow rate} = V_{a1} \times \frac{A}{V_s} = 77.65 \times \frac{0.288}{0.198} = 112.95 \text{ kg/s}$$

$$(5) \text{ Power} = m \times V_b \times (V_{r1} - V_{r0}) \text{ kW}$$

from velocity triangle  $V_{r1} - V_{r0} = 288 \text{ m/s}$

$$\text{power} = 112.95 \times 144 \times \frac{288}{1000} = 4682 \text{ kW}$$

$$(6) \text{ Diagram efficiency} = 2 \times V_b \times \frac{(V_{r1} - V_{r0})}{V_1^2} = 92.16$$

$$\text{stage efficiency} = \text{diagram efficiency} \times \eta_n = 0.9216 \times 0.92$$

**Example 2.** An impulsive stage of a steam turbine is supplied with dry and saturated steam at 14.7 bar. The stage has a single row of moving blades running at 3600 rev/min. The mean diameter of the blade disc is 0.9 m. The nozzle angle is  $15^\circ$  and the axial component of the absolute velocity leaving the nozzle is 93.42 m/s. The height of the nozzles at their exit is 100 mm. The nozzle efficiency is 0.9 and the blade velocity co-efficiency is 0.966. The exit angle of the moving blades is  $2^\circ$  greater than at the inlet. Determine:

- (1) The blade inlet and outlet angles.
- (2) The isentropic heat drop in the stage.
- (3) The stage efficiency.
- (4) The power developed by the stage

$$\text{Solution. Mean blade velocity, } V_b = \frac{\pi D N}{60} = 3.14 \times 0.9 \times \frac{3600}{60} = 169.65 \text{ m/s}$$

$$\alpha = 15^\circ ; V_{a1} = 93.42 \text{ m/s}$$

$$\text{Now } V_{a1} = V_1 \sin \alpha ; V_1 = \frac{V_{a1}}{\sin \alpha} = 360.95 \text{ m/s}$$

With this, inlet velocity triangle can be completed

From there:  $\theta = 29.5^\circ$   $V_{r1} = 202.5 \text{ m/s}$

$$\phi = 29.5 + 2 = 31.5 ; V_{r0} = 0.966 \times V_{r1} = 195 \text{ m/s}$$

With this, the outlet velocity triangle can be completed

$$\theta = 29.5^\circ, \phi = 31.5^\circ$$

Now for dry and saturated steam at 14.7 bar;  $V_s = 0.1392 \text{ m}^3/\text{kg}$

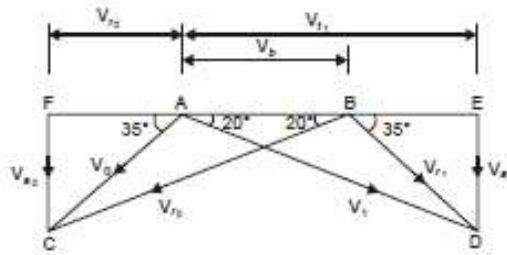

$$\text{Power} = m \times V_b \times \frac{(V_{a1} - V_{a2})}{1000} \text{ kW}$$

$$= 4.54 \times 67 \times \frac{212}{1000} = 64.47 \text{ kW}$$

at 1.373 bar, dry saturated

$$V_s = 1.259 \text{ m}^3/\text{Kg} \quad (\text{from steam table})$$

$$\text{Now} \quad m = \pi D \times D \times \frac{V_d}{V_s} \times 10$$

From velocity triangle,

$$V_a = 50 \text{ m/s}$$

$$D^2 = 4.54 \times 1.259 \times \frac{10}{\rho \times 50} = 0.3$$

$$D = 0.5477 \text{ m}$$

$$h = 5.477 \text{ cm}$$

$$\text{Heat drop required} = \frac{74.47}{0.8} = 80.58 \text{ kJ/kg}$$

# ***MODULE-III***

## ***NUCLEAR POWER PLANT***

### **10.1 INTRODUCTION**

There is strategic as well as economic necessity for nuclear power in the United States and indeed most of the world. The strategic importance lies primarily in the fact that one large nuclear power plant saves more than 50,000 barrels of oil per day. At \$30 to \$40 per barrel (1982), such a power plant would pay for its capital cost in a few short years. For those countries that now rely on but do not have oil, or must reduce the importation of foreign oil, these strategic and economic advantages are obvious. For those countries that are oil exporters, nuclear power represents an insurance against the day when oil is depleted. A modest start now will assure that they would not be left behind when the time comes to have to use nuclear technology.

The unit costs per kilowatt-hour for nuclear energy are now comparable to or lower than the unit costs for coal in most parts of the world. Other advantages are the lack of environmental problems that are associated with coal or oil-fired power plants and the near absence of issues of mine safety, labor problems, and transportation bottle-necks. Natural gas is a good, relatively clean-burning fuel, but it has some availability problems in many countries and should, in any case, be conserved for small-scale industrial and domestic uses. Thus nuclear power is bound to become the social choice relative to other societal risks and overall health and safety risks.

Other sources include hydroelectric generation, which is nearly fully developed with only a few sites left around the world with significant hydroelectric potential. Solar power, although useful in outer space and domestic space and water heating in some parts of the world, is not and will not become an economic primary source of electric power.

Yet the nuclear industry is facing many difficulties, particularly in the United States, primarily as a result of the negative impact of the issues of nuclear safety waste disposal, weapons proliferation, and economics on the public and government. The impact on the public is complicated by delays in licensing proceedings, court and ballot box challenges. These posed severe obstacles to electric utilities planning nuclear power plants, the result being scheduling problems, escalating and unpredictably costs, and economic risks even before a construction permit is issued. Utilities had a delay or cancel nuclear projects so that in the early 1980s there was a de facto moratorium on new nuclear plant commitments in the United States.

It is, however, the opinion of many, including this author, that despite these difficulties the future of large electric-energy generation includes nuclear energy as a primary, if not the main, source. The signs are already evident in many European and Asian countries such as France, the United Kingdom, Japan, and the U.S.S.R.

308 POWER PLANT ENGINEERING

In a power plant technology course, it is therefore necessary to study nuclear energy: systems.

We shall begin in this chapter by covering the energy-generation processes in nuclear reactors by starting with the structure of the atom and its nucleus and reactions that give rise to such energy generation.

These include fission, fusion, and different types of neutron-nucleus interactions and radioactivity.

### **10.2 GENERAL HISTORY AND TRENDS**

#### **10.2.1 MAJOR EVENTS**

**1945** : “Nuclear energy emerged from scientific obscurity and military secrecy.”

**1945-55** : “An enthusiastic vision developed of a future in which nuclear power would provide a virtually unlimited solution for the world’s energy needs.”

**1955-73** : The pros and cons of nuclear energy were debated; however, the optimists prevailed and nuclear energy grew to become an important source of electricity.

**Pros** : Abundant, clean, and cheap energy. (We now know nuclear energy is not cheap.)

**Cons** : Large amounts of radioactivity are produced in the nuclear reactor, mishaps cannot be totally ruled out, and nuclear energy cannot be divorced from nuclear weapons. (Also, the long-term storage of nuclear wastes is now a very important issue.)

**1955-65** : Many reactors designed, built, and put into operation.

**1965-73** : Most of the US reactors were ordered during this period.

**1973-85** : Many US reactors canceled during this period.

**1970-90** : Most US reactors licensed to operate during this period.

**1990-present** : The number of nuclear reactors operating in the US and in the world leveled off, reaching a plateau. Few new reactors ordered and built.

Nuclear reactors started producing electricity in a significant way beginning about 1970 — just before the first international oil crisis in 1973. Thus, many countries saw nuclear energy as a means to reduce dependency on foreign oil. The US government saw nuclear energy as an important key to “energy independence.”

However, the 1973 oil crisis led to “side effects,” which adversely affected nuclear energy:

Attention was focused worldwide on reducing energy consumption, including the consumption of electricity. (During the 1973-86 period, energy growth was erratic. Overall in the US, energy grew about as fast as the population, whereas electricity grew about as fast as the GNP, which means it grew faster than overall energy consumption, though not as fast as it had grown prior to 1973.

The oil crises reduced economic growth, thus, decreasing the demand for energy and electricity.

These effects reduced the demand for new nuclear plants. By 1973, the cost of nuclear energy was no longer regarded as “cheap,” as had been touted in the early days of nuclear energy development, and safety concerns were starting to have an impact on the public view of nuclear energy. Also, nuclear energy was regarded as “establishments,” and there were many protests against the establishment and its programs.

US nuclear energy capacity has been steady since the late 1980s. Currently, about 22% of US electricity is generated from nuclear energy (7.17 Quads). In 1994, there were 109 operating nuclear reactors in the US, with a total capacity of 99GWe. Currently, nuclear energy represents about 8% of the

NUCLEAR POWER PLANT 309  
primary energy consumption in the US. However, coal is “king,” generating about 55% of US electricity. Hydro generates about 10% of US electricity.

The US generates more electricity from nuclear energy than any other nation. However, France generates the greatest percentage of electricity from nuclear energy — about 75-80%. France is followed by Sweden. In 1994, Sweden generated about 50% of its electricity from nuclear energy, but now says it is getting out of nuclear energy electricity generation. The Swedish government claims this move will not increase its greenhouse gas emissions — a claim not believed in all circles.

Worldwide, for 1994, nuclear energy accounted for 6% of the primary energy consumption and 18% of the electricity generation. These numbers are just below the values for the US. 424 nuclear reactors operate worldwide, with a total capacity of 338GWe, spread over 30 countries.

In all but a few countries, nuclear energy growth was brought to a stop or at least to a crawl in the late 1980s and the 1990s. A summary of the reasons is:

- Reduction in oil and gas prices, especially since the late 1980s.
- Reduced growth in energy, compared to the pre-1973 period.
- Rising cost of nuclear energy.
- Increasing fears about nuclear energy.
- Campaigns against nuclear energy.

Public interest in nuclear energy began about 1944, grew strongly until about 1974, reached its peak then, and by 1994 dropped to a low level.

Is the age of nuclear energy over? Outside of a few countries, will more reactors be built? Has the verdict been given on nuclear energy?

### **10.2.2 WHAT MIGHT CHANGE THE CURRENT SITUATION?**

**Cost.** Currently, nuclear energy is regarded as costly, and some costs are surely being passed on to future generations. The euphoric claims of the 1940s and 1950s regarding low cost nuclear energy

have been discounted for at least two decades. The statement of the 1950s that nuclear energy would be “too cheap to meter” has haunted the industry. However, the text states that nuclear energy was cheaper than fossil energy for a period in the 1970s, and today is cheaper than fossil energy in some countries. In the US, the long construction times, of about 10 years, have significantly driven up the cost. During construction period, capital is invested, interest payments occur, but no income from the sale of electricity occurs.

The development of factory-built, packaged, nuclear reactors, which could be purchased much as combined cycle combustion turbines are done today, would probably significantly reduce the cost. “From order to operation” within 2 or 3 years would be quite a change.

Standardization of nuclear reactor designs would likely significantly reduce the cost, and would likely increase safety.

Two things should be noted about US reactors. Many designs were developed and built. And most of the US reactors were ordered over a very short period of time, 1965 to 1973. Thus, during the 1970s and 1980s the opportunity to “get out the bugs,” and for the better systems to evolve and win out didn’t fully occur. With the benefit now of experience, with standardization, and with reduced order-

to-start-up times, the cost of nuclear energy should come down.

310 POWER PLANT ENGINEERING

**Public Attitude.** The public requires assurance that the industry truly has the issues of safety, fuel security, and waste disposal well under control. Perhaps the French experience will be convincing in this regard.

**Greenhouse Effect.** If the public comes to fear greenhouse warming, rather than simply having a concern about it, as currently the case, nuclear energy may be viewed more favorably. Coal is the “real” problem with respect to greenhouse gases. More electricity is produced by the burning of coal than by any other method. If the world continues to produce much of its electricity from coal, the evidence is fairly strong: CO<sub>2</sub> concentrations in the atmosphere will significantly increase, and greenhouse warming will occur (though the level of temperature increase is uncertain). Burning of all of the earth’s fossil fuel resources would probably increase the atmospheric CO<sub>2</sub> concentration from the current level of 360 ppmv to about 1300 ppmv. 90% of this increase would be due to coal, since the oil and gas resources are small compared to the coal resources. The calculation assumes 4000 Gte (giga tonnes) of carbon in the earth’s fossil fuel resources, an increase of 1ppmv CO<sub>2</sub> in the atmosphere for every 2.13 Gte of carbon burned, and a retention of 50% of the emitted CO<sub>2</sub> in the atmosphere. Since the start of the industrial age in the late 1700s, the CO<sub>2</sub> content of the atmosphere has increased about 80 ppmv, and the mean temperature of the earth’s atmosphere near the surface has increased about 1 degree F. If the temperature rise is assumed to be due to the CO<sub>2</sub> increase (which is debatable), a linear extrapolation implies a temperature increase of 12 degrees F for the 360 to 1300 ppmv CO<sub>2</sub> increase.

**Demand for Electricity.** Electricity is a desirable and convenient form of energy. Several factors could influence the demand for its generation, including its generation from nuclear power stations:

- Greater use of electricity, relative to heat, for manufacturing processes — a trend likely to continue and to drive up demand for electricity.
- Greater use of heat pumps for space heating. Significant growth here is problematic, since gas is cheap, and for many, heating with gas-fired furnaces is cheaper than converting to electric driven heat pumps.
- Electrification of transportation systems : Electric vehicles (EVs) and some types of hybrid electric vehicles (HEVs) depend on an external source of electricity. However, other types of HEVs and fuel cell powered vehicles generate electricity on board. It is too early to judge which system will evolve, or whether the internal combustion engine will retain predominance in a new form. Thus, a significant increase in electricity for the transportation sector is difficult to judge at present. See the front page of the Wall Street Journal for Monday, January 5, 1998 for an article on new power plants for automobiles.
- Combined cycle combustion turbines, fired on gas, are rapidly gaining popularity for generating electricity. Capital cost is relatively low, first law efficiency is high and will go higher (at least 60%), and order-to-start-up time is short. These systems may diminish the interest in new nuclear energy technology over the next one to two decades. Long term availability and price stability of the natural gas is the concern with respect to these systems. Also, they emit greenhouse gases, though the amount of CO<sub>2</sub> emitted per unit of electrical energy produced is less than one half that of a coal-fired electric power generating station.



- Renewable energy technology : What will be the growth of solar, wind, biomass, and other renewable energy technologies ? Will their cost competitiveness improve ? Are they as environmentally benign as thought ? Will they fill more than niche markets? Will technological breakthroughs occur ? Could they increase from 8% of US primary energy consumption (the current situation) to say the 20 to 30% level within 10 to 20 years ? If “yes,” renewable energy may diminish the rejuvenation of the nuclear energy industry.

NUCLEAR POWER PLANT 311

### 10.2.3 TECHNICAL HISTORY AND DEVELOPMENTS

#### Developments Prior to and During WW-2

- 1896: discovery of radioactivity.
- 1911: discovery of the nuclear atom.
- 1911: Rutherford noted the enormous amount of energy associated with nuclear reactions compared to chemical reactions.
- 1932: discovery of neutron.
- 1938: discovery of nuclear fission.
- 1939: researchers recognized that enough neutrons were released during fission reactions to sustain a chain reaction (in a pile of uranium and graphite). A chain reaction requires the release of two neutrons (or more) for every neutron used to cause the reaction.
- 1942 (Dec. 2): demonstration of the first operating nuclear reactor (200 Watts).
- 1943 (Nov.): 1 mW reactor put into operation at Oak Ridge, Tennessee.
- 1944 (Sept.): 200 mW reactor put into operation at Hanford, Washington—for the production of plutonium. This reactor was built in only 15 months.
- 1944 (Sept.): nuclear reactor for electricity generation proposed, using water for both cooling and neutron moderation. Essentially, this is the birth of nuclear energy for civilian use.

#### 10.2.4 DEVELOPMENTS AFTER WW-2

- 1946: AEC (Atomic Energy Commission) established to oversee both military and civilian nuclear energy.
- 1953: Putman report/book, a thoughtful analysis of the case for nuclear energy for electricity production.
- 1953: US Navy began tests of the PWR (pressurized water reactor).
- 1957: 60 mW reactor at Shippingport, PA began to generate electricity for commercial use. The plant was built by the AEC, though Navy leadership played a predominant role.
- 1953-60: exploratory period: 14 reactors built, of many different designs, all but 3 under 100 mW size.
- 1960-65: only 5 reactors built.
- 1965-73: main period of ordering of nuclear reactors in the US. Size was much larger than before, many reactors of 600 to 1200 mW size.
- 1974: “honeymoon” over-nuclear energy no longer highly valued by the public.
- 1973-78: fall off in orders, with no US orders after 1978.
- 1974-85: cancellation of orders, over half of orders were canceled, or construction never brought to completion. Most reactors ordered prior to 1970 were built and brought on line. Many reactors ordered after 1970 never came on line they were canceled.
- 1970-90: most of US’s reactors brought on line for commercial operation, indicating that most US reactors are 7 to 27 years old, or have 13 to 33 years of operation left, assuming a 40 year operating life.
- 1979: Three Mile Island accident. Reactor shut down.

312 POWER PLANT ENGINEERING

- 1986: Chernobyl accident.
- Early 1990s: 7 nuclear reactors shut down, including 3 of early design and 4 of marginal performance. These shutdowns do not necessarily mean that a steady stream of reactors will be shut down before their nominal life of 40 years is reached.
- 1990s: Shoreham (Long Island) reactor shut down for good by public protest.

**Capacity.** Capacity factor (or capacity) = actual energy output integrated over a set period of time divided by the energy that would have occurred over the period of time if the reactor had been operated at rated power.

Routine maintenance and variations in demand limit maximum capacity to about 90%.

Long-term capacity over 80% is considered very good.



### 10.3 THE ATOMIC STRUCTURE

In 1803 John Dalton, attempting to explain the laws of chemical combination, proposed his simple but incomplete atomic hypothesis. He postulated that all elements consist of indivisible minute particles of matter, atoms, that were different for different elements and preserved their identity in chemical reactions. In 1811 Amadeo Avogadro introduced the molecular theory based on the molecule, a particle of matter composed of a finite number of atoms. It is now known that the atoms are themselves composed of sub particles, common among atoms of all elements.

An atom consists of a relatively heavy, positively charged nucleus and a number of much lighter negatively charged electrons that exist in various orbits around the nucleus. The nucleus, in turn, consists of sub particles, called nucleons. Nucleons are primarily of two kinds: the neutrons, which are electrically neutral, and the proton: which are positively charged. The electric charge on the proton is equal in magnitude but opposite in sign to that on the electron. The atom as a whole is electrically neutral the number of protons equals the number of electrons in orbit. One atom may be transformed into another by losing or acquiring some of the above sub particles. Such reactions result in a change in mass  $\Delta m$  and therefore release (or absorb) large quantities of energy  $\Delta E$ , according to Einstein's law

$$\Delta E =$$

$\Delta mc^2$

where  $c$  is the speed of light in vacuum and  $g$ , is the familiar engineering conversion factor. Equation

$$\Delta E = \Delta mc^2 \dots (10.1)$$

(10.1) applies to all processes, physical, chemical, or nuclear, in which energy is released or absorbed. Energy is, however, classified as *nuclear* if it is associated with changes in the atomic nucleus.

Figure 10.1 shows three atoms. Hydrogen has a nucleus composed of one proton, no neutrons, and one orbital electron. It is the only atom that has no neutrons. Deuterium has one proton and one neutron in its nucleus and one orbital electron. Helium contains two protons, two neutrons, and two electrons. The electrons exist in orbits, and each is quantized as a lumped unit charge as shown. Most of the mass of the atom is in the nucleus. The masses of the three primary atomic sub particles are

Neutron mass  $m_n = 1.008665$  amu

Proton mass  $m_p = 1.007277$  amu

Electron mass  $m_e = 0.0005486$  amu. The abbreviation amu, for *atomic mass unit*, is a unit of mass approximately equal to  $1.66 \times 10^{-27}$  kg, or  $3.66 \times 10^{-2}$  lb. These three particles are the primary building blocks of all atoms. Atoms differ in their mass because they contain varying numbers of them.

NUCLEAR POWER PLANT 313

Atoms with nuclei that have the same number of protons have similar chemical and physical characteristics and differ mainly in their masses. They are called *isotopes*. For example, deuterium, frequently called *heavy hydrogen*, is an isotope of hydrogen. It exists as one part in about 6660 in naturally occurring hydrogen. When combined with oxygen, ordinary hydrogen and deuterium form *ordinary water* (or simply water) and *heavy water*, respectively.

The number of protons in the nucleus is called the *atomic number Z*. The total number of nucleons in the nucleus is called the *mass number A*.

(a) (b) (c)

= neutron = proton = electron

**Fig. 10.1**

As the mass of a neutron or a proton is nearly 1 amu,  $A$  is the integer nearest the mass of the nucleus which in turn is approximately equal to the atomic mass of the atom. Isotopes of the same element thus have the same atomic number but differ in mass number. Nucleus symbols are written conventionally as

${}^Z X_A$

where  $X$  is the usual chemical symbol. Thus the hydrogen nucleus is  ${}^1_1\text{H}$ , deuterium is  ${}^2_1\text{H}$  (and sometimes  $\text{D}$ ), and ordinary helium is  ${}^4_2\text{He}$ . For particles containing no protons, the subscript indicates the magnitude and sign of the electric charge. The electron is  $-e^-$  (sometimes  $e^-$  or  $\ominus$ ) and a neutron is  ${}^0_0n$ . Symbols are also often written in the form He-4, helium-4, etc. Another system of notation, written as  ${}^A_Z X$ , will not be used in this text.

Fig. 10.2 shows, schematically, the structure of  $\text{H}_1$ ,  $\text{He}_4$  and some heavier atoms and the distribution of their electrons in various orbits. Two other particles of importance are the positron and the neutrino. The *positron* is a positively charged electron having the symbols  $+e^+$ ,  $e^+$  or  $\oplus$ . The neutrino (little neutron) is a tiny electrically neutral particle that is difficult to observe experimentally. Initial evidence of its existence was based on theoretical considerations, nuclear reactions where  $1/3$  particle of

either kind is emitted or captured, the resulted energy (corresponding to the lost mass) was not all accounted for by the energy the emitted  $\alpha$  particle and the recoiling nucleus. It was first suggested by Wolfgang Pauli in 1934 that the neutrino was simultaneously ejected in these reactions and the it carried the balance of the energy, often larger than that carried by the  $\alpha$  particle itself. The importance of neutrinos

is that they carry some 5 percent of the total energy produced in fission. This energy is completely react lost because neutrinos do not react and are not stopped by any practical structural material. The neutrino is given the symbol  $\nu$ .

There are many other atomic sub particles. An example is the *mesons*, unstable positive, negative, or neutral particles that have masses intermediate between an electron and a proton. They are exchanged between nucleons and are thought to account for the forces between them. A discussion of these and other sub particles is, however beyond the scope of this book.

Electrons that orbit in the outermost shell of an atom are called *valence electron*. The outermost shell is called the *valence shell*. Thus, hydrogen has one valence electron and its K shell is the valence

314 POWER PLANT ENGINEERING

shell, etc. Chemical properties of an element are function of the number of valence electrons. The electrons play little or not part nuclear interactions.

e  
n  
p  
(d)  
e  
n  
p  
e  
e  
(c)  
n  
p  
e  
e  
(b)  
p  
e  
(a)  
e  
p  
n  
(e) (f)  
e  
15p  
16n  
(g)  
54p  
71n  
e

Fig. 10.2

## 10.4 SUMMARY OF NUCLEAR ENERGY CONCEPTS AND TERMS

### 10.4.1 SUMMARY OF FEATURES

1. Heat energy source is fission of radioactive material, (U-235)
2. Two typical plant designs:  
Pressurized water reactor (PWR) (U.S.)  
Boiling water reactor (BWR) (Russian)
3. Fuel pellets are in a large number of tubes (fuel rods)
4. Water circulates through core
5. Water converted to steam drives turbine
6. Turbine turns generator electricity

### 10.4.2 FISSION

Unstable (radioactive) elements spontaneously split (radioactive decay), emitting high energy particles. Collision of particles with other atomic nuclei can trigger further nuclear decompositions. A small amount of mass is converted into a large amount of energy, when atomic nuclei are split.

*Einstein equation:  $E = mc^2$*

Conversion of mass to energy.  $E$  = energy,  $m$  = mass converted,  $c$  = speed of light

### 10.4.3 CRITICAL MASS

There is a threshold mass of a radioactive isotope at which the flux density of radioactive particles will sustain a chain reaction. If this reaction is uncontrolled the result is an atomic bomb explosion. If the radiation fluxes are controlled and limited, we call it a nuclear reactor, which can be the basis of an electric power plant.

#### Types of Radiation Atomic Weight Charge

Alpha radiation (Helium nucleus) 4 +2

Beta radiation (Electron) ~0 - 1

Neutron 1 0

Gamma ray ~0 0

### 10.4.4 ALPHA RADIATION

Alpha is quickly absorbed by matter because the particles have a large probability of collision with nuclei. Sources external to the human body cause radiation absorption within the thickness of the skin. Radiation from airborne particles in the lung are absorbed by surface membranes lining the lung. Alpha emitters ingested with food cause radiation absorption by the lining of the gut. The risk of genetic damage to adult organisms is very small because absorption takes place in surface cells.

### 10.4.5 BETA PARTICLES

Beta particles penetrate to the deepest parts of the body and can cause genetic damage and disrupt the function of cells anywhere in the body. Building walls and earthwork provide substantial shielding.

### 10.4.6 GAMMA PARTICLES

Gamma has the greatest penetration due to their small cross-section. Gamma particles can pass through ordinary materials. Effective shielding requires blankets of lead. Gamma radiation is a danger to all cells in the body.

### 10.4.7 URANIUM FISSION

${}_{92}\text{U}^{235} + {}_0^1\text{n} \rightarrow {}_{92}\text{U}^{236} \rightarrow \text{Fission Products}$

${}_{92}\text{U}^{238} + {}_0^1\text{n} \rightarrow {}_{92}\text{U}^{239} + \text{Gamma} \rightarrow \text{Fission Products}$

${}_{92}\text{U}^{239} \rightarrow {}_{93}\text{Np}^{239} \rightarrow {}_{94}\text{Pu}^{239}$

Neptunium Plutonium

After many steps, (and a long time) the ultimate product is non-radioactive Lead atoms. The neutrons, whose absorption is indicated above, come from splitting of later fission products in reactions not shown here. Note that U-235 fission in the presence of U-238 causes the conversion of part of the U-238 into Plutonium-239 which can be concentrated to make an H-Bomb. Intermediate isotopes of health significance include Cesium-137, Iodine-131, Strontium-90 and many others.

316 POWER PLANT ENGINEERING

### 10.4.8 HALF LIFE, T

Time for half the atomic nuclei to spontaneously split. The amount decays exponentially

$$N = N_0 \exp(-t/T)$$

N = Amount of radioactive material,

$N_0$  = Initial amount,

t = Elapsed time

## 10.5 ETHICAL PROBLEMS IN NUCLEAR POWER REGULATION

The Atomic Energy Commission (AEC), was formed to create a civilian nuclear energy industry, and had conflicting responsibilities:

#### • Promoting Nuclear Power

—funded research in plant design

—subsidized production of nuclear fuel

#### • Regulating Plant Safety

—defined safety procedures, poor enforcement

—inspecting, certifying plants

—certifying operators, poor training

As a result of these conflicting interests

#### • No Long Term Waste Disposal Plan was Completed

—wastes are still accumulating in temporary storage

—radioactive waste? NIMBY

#### • Future Termination/Cleanup Costs are not Factored into Current Electric Rates

#### • Power Companies are Largely Self-Regulated

—avoid reporting radiation release or do not monitor releases.

—avoid safety regulations to save money.

Internal conflicts of the AEC were supposed to be resolved by splitting the promotional and regulatory duties between the new agencies:

Nuclear Regulatory Commission (NRC) – safety and standards

Dept. of Energy (DOE) – research, promotion, waste disposal, and fuel rod production.

## 10.6 CHEMICAL AND NUCLEAR EQUATIONS

Chemical reactions involve the combination or separation of whole atoms.

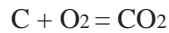

This reaction is accompanied by the release of about 4 electron volts (eV). An *electron volt* is a unit of energy in common use in nuclear engineering.  $1 \text{ eV} = 1.6021 \times 10^{-19} \text{ joules (J)} = 1.519 \times 10^{-22} \text{ Btu} = 4.44 \times 10^{-26} \text{ kWh}$ . 1 million electron volts (1 MeV) = 106 eV.

In chemical reactions, each atom participates as a whole and retains its identity. The molecules change. The only effect is a sharing or exchanging of valence electrons. The nuclei are unaffected. In

NUCLEAR POWER PLANT 317  
chemical equations there are as many atoms of each participating element in the products (the right-hand side) as in the reactants (the left-hand side). Another example is one in which uranium dioxide (UO<sub>2</sub>) is converted into uranium tetra fluoride (UF<sub>4</sub>), called green salt, by heating it in an atmosphere of highly corrosive anhydrous (without water) hydrogen fluoride (HF), with water vapor (H<sub>2</sub>O) appearing in the products

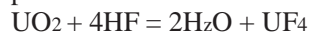

Water vapor is driven off and UF<sub>4</sub> is used to prepare gaseous uranium hexafluoride (UF<sub>6</sub>), which is used in the separation of the U<sub>235</sub> and U<sub>238</sub> isotopes of uranium by the gaseous diffusion method. (Fluorine has only one isotope, F<sub>9</sub>, and thus combinations of molecules of uranium and fluorine have molecular masses depending only on the uranium isotope.)

Both chemical and nuclear reactions are either *exothermic* or *endothermic*, that is, they either release or absorb energy. Because energy and mass are convertible, Eq. (10.1), chemical reactions involving

energy do undergo a mass decrease in exothermic reactions and a mass increase in endothermic ones. However, the quantities of energy associated with a chemical reaction are very small compared with those of a nuclear reaction, and the mass that is lost or gained is minutely small. This is why we assume a preservation of mass in chemical reactions, undoubtedly an incorrect assumption but one that is sufficiently accurate for usual engineering calculations.

In nuclear reactions, the reactant nuclei do not show up in the products, instead we may find either isotopes of the reactants or other nuclei. In balancing nuclear equations it is necessary to see that the same, or equivalent, nucleons show up in the products as entered the reaction. For example, if K, L, M, and N were chemical symbols, the corresponding nuclear equation might look like



To balance the following relationship must be satisfied.

$$Z_1 + Z_2 = Z_3 + Z_4$$

$$A_1 + A_2 = A_3 + A_4$$

Sometimes the symbols  $\gamma$  or  $\nu$  are added to the products to indicate the emission of electromagnetic radiation or a neutrino, respectively. They have no effect on equation balance because both have zero Z and A, but they often carry large portions of the resulting energy.

Although the mass numbers are preserved in a nuclear reaction, the masses of the isotopes on both sides of the equation do not balance. Exothermic or endothermic energy is obtained when there is a reduction or an increase in mass from reactants to products, respectively.

## 10.7 NUCLEAR FUSION AND FISSION

Nuclear reactions of importance in energy production are fusion, fission, and radioactivity. In fusion, two or more light nuclei fuse to form a heavier nucleus. In fission, a heavy nucleus is split into two or more lighter nuclei. In both, there is a decrease in mass resulting in exothermic energy.

The same as in force =

1

g

,  $\times \text{mass} \times \text{acceleration}$ .

318 POWER PLANT ENGINEERING

**Table 10.1. Mass-energy Conversion factors**

**Energy**

**Mass MeV J Bru kWh mW day**

amu 931.478 1.4924 × 10<sup>-10</sup> 1.4145 × 10<sup>-13</sup> 4.1456 × 10<sup>-17</sup> 9.9494 × 10<sup>-13</sup>  
 kg 5.6094 × 10<sup>29</sup> 8.9873 × 10<sup>16</sup> 8.5184 × 10<sup>13</sup> 2.4965 × 10<sup>10</sup> 5.9916 × 10<sup>14</sup>  
 lb<sub>m</sub> 2.5444 × 10<sup>29</sup> 4.0766 × 10<sup>16</sup> 3.8639 × 10<sup>23</sup> 1.1324 × 10<sup>10</sup> 2.7177 × 10<sup>14</sup>

**10.7.1 FUSION**

Energy is produced in the sun and stars by continuous fusion reactions in which four nuclei of hydrogen fuse in a series of reactions involving other particles that continually appear and disappear in the course of the reactions, such as He, nitrogen, carbon, and other nuclei, but culminating in one nucleus of helium and two positrons resulting in a decrease in mass of about 0.0276 amu, corresponding to 25.7 MeV.



The heat produced in these reactions maintains temperatures of the order of several million degrees in their cores and serves to trigger and sustain succeeding reactions. On earth, although fission preceded fusion in both weapons and power generation. the basic fusion reaction was discovered first, in the 1920s, during research on particle accelerators. Artificially produced fusion may be accomplished when two light atom fuse into a larger one as there is a much greater probability of two particles colliding than of four. The 4-hydrogen reaction requires, on an average, billions of years for completion, whereas the deuterium-deuterium reaction requires a fraction of a second. To cause fusion, it is necessary to accelerate the positively charged nuclei to high kinetic energies, in order to overcome electrical repulsive forces, by raising their temperature to hundreds of millions of degrees resulting in a plasma. The plasma must be prevented from contacting the walls of the container, and must be confined for a period of time (of the order of a second) at a minimum density. Fusion reactions are called *thermonuclear* because very high temperatures are required to trigger and sustain them. Table 10.2 lists the possible fusion reactions and the energies produced by them.

**Table 10.2**

**Fusion reaction**

**Energy per**

**Number Reactants Products reaction, MeV**

- 1 D + D T + p 4
- 2 D + D He<sub>3</sub> + n 3.2
- 3 T + D He<sub>4</sub> + n 17.6
- 4 He<sub>3</sub> + D He<sub>4</sub> + p 18.3

*n, p, D, and T* are the symbols for the neutron, proton, deuterium and tritium respectively.

**NUCLEAR POWER PLANT 319**

Many problems have to be solved before an artificially made fusion reactor becomes a reality . The most important of these are the difficulty in generating and maintaining high temperatures and the instabilities in the medium (plasma), the conversion of fusion energy to electricity, and many other problems of an operational nature. Fusion power plants will not be covered in this text.

**10.7.2 Fission**

Unlike fusion, which involves nuclei of similar electric charge and therefore requires high kinetic energies, fission can be caused by the neutron, which, being electrically neutral, can strike and fission the positively charged nucleus at high, moderate, or low speeds without being repulsed. Fission can be caused by other particles, but neutrons are the only practical ones that result in a sustained reaction because two or three neutrons are usually released for each one absorbed in fission. These keep the reaction going. There are only a few fissionable isotopes U<sub>235</sub>, Pu<sub>239</sub> and U<sub>233</sub> are fissionable by neutrons of all energies.

The immediate (prompt) products of a fission reaction, such as Xe<sup>o</sup> and Sr<sub>γ4</sub> above, are called fission fragments. They, and their decay products , are called fission products. Fig. 10.4 shows fission product data for U<sub>235</sub> by thermal and fast neutrons and for U<sub>233</sub> and Pu<sub>239</sub> by thermal neutrons 1841. The products are represented by their mass numbers.

Neutron  
 Uranium nucleus  
 Xenon nucleus Neutron lost by escape or consumed in nonfission reaction  
 Strontium nucleus

**Fig. 10.3**

10  
 1.0  
 0.1  
 0.01

0.001  
0.0001  
70 80 90 100 110 120 130 140 150  
U  
<sup>239</sup>Pu  
<sup>239</sup>Pu  
<sup>235</sup>U  
<sup>239</sup>Pu  
Pu Fission yield per cent  
Mass number  
(b)  
Thermal  
4 Mev  
10  
1.0  
0.1  
0.01  
0.001  
0.0001  
70 80 90 100 110 120 130 140 150 160  
Fission yield per cent  
Mass number  
(a)  
Thermal neutrons  
14 Mev neutrons

**Fig. 10.4**

320 POWER PLANT ENGINEERING

## 10.8 ENERGY FROM FISSION AND FUEL BURN UP

There are many fission reactions that release different energy values. Another

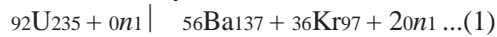

has the mass balance

$$235.0439 + 1.00867 \mid 136.9061 + 96.9212 + 2 \times 1.00867$$

$$236.0526 \mid 235.8446$$

$$\Delta m = 235.8446 - 236.0526 = -0.2080 \text{ amu} \dots(2)$$

$$\text{Thus } \Delta E = 931 \times -0.2080 = -193.6 \text{ MeV} = -3.1 \times 10^{-11} \text{ J} \dots(3)$$

On the average the fission of a  $\text{U}^{235}$  nucleus yields about 193 MeV. The same figure roughly applies to  $\text{U}^{233}$  and  $\text{Pu}^{239}$ . This amount of energy is prompt, *i.e.*, released at the time of fission. More energy, however, is produced because of (1), the slow decay of the fission fragments into fission products and (2) the nonfission capture of excess neutrons in reactions that produce energy, though much less than that of fission.

The *total energy*, produced *per* fission reaction, therefore, is greater than the prompt energy and is about 200 MeV, a useful number to remember.

The complete fission of 1 g of  $\text{U}^{235}$  nuclei thus produces

${}^{235}\text{U}$

Avogadro's number

U isotope mass

$$= 200 \text{ MeV} =$$

$$0.60225 \times 10^{24}$$

$$235.0439$$

.

$$\times 200$$

$$= 0.513 \times 10^{24} \text{ MeV} = 2.276 \times 10^{24} \text{ kWh}$$

$$= 8.190 \times 10^{10} \text{ J} = 0.948 \text{ MW-day.}$$

Another convenient figure to remember is that a reactor burning 1 g of fissionable material generates nearly 1 MW-day of energy. This relates to fuel burnup. Maximum theoretical burnup would therefore be about a million MW-day/ton (metric) of fuel. This figure applies if the fuel were entirely composed of fissionable nuclei and all of them fission. Reactor fuel, however, contains other nonfissionable

isotopes of uranium, plutonium, or thorium. Fuel is defined as all uranium, plutonium, and thorium isotopes. It does not include alloying or other chemical compounds or mixtures. The term fuel material is used to refer to fuel plus such other materials.

Even the fissionable isotopes cannot be all fissioned because of the accumulation of fission products that absorb neutrons and eventually stop the chain reaction. Because of this—and owing to metallurgical reasons such as the inability of the fuel material to operate at high temperatures or to retain gaseous fission products [such as Xe and Kr, in its structure except for limited periods of time—burnup values are much lower than this figure. They are, however, increased somewhat by the fissioning of



some fissionable nuclei, such as  $\text{Pu}_{239}$ , which are newly converted from fertile nuclei, such as  $\text{U}_{238}$  (Sec. 10.4.7). Depending upon fuel type and *enrichment* (mass percent of fissionable fuel in all fuel), burnups may vary from about 1000 to 100,000 MW-day/ton and higher.

## 10.9 RADIOACTIVITY

Radioactivity is an important source of energy for small power devices and a source of radiation for use in research, industry, medicine, and a wide variety of applications, as well as an environmental concern.

NUCLEAR POWER PLANT 321

Most of the naturally occurring isotopes are stable. Those that are not stable, *i.e.*, *radioactive*, are some isotopes of the heavy elements thallium ( $Z = 81$ ), lead ( $Z = 82$ ), and bismuth ( $Z = 83$ ) and all the isotopes of the heavier elements beginning with polonium ( $Z = 84$ ). A few lower-mass naturally occurring isotopes are radioactive, such as  $\text{K}_{40}$ ,  $\text{Rb}_{87}$  and  $\text{In}_{115}$ . In addition, several thousand artificially produced isotopes of all masses are radioactive. Natural and artificial radioactive isotopes, also called *radioisotopes*, have similar disintegration rate mechanisms. Fig. 10.5 shows a Z-N chart of the known isotopes.

*Radioactivity* means that a radioactive isotope continuously undergoes spontaneous (*i.e.*, without outside help) disintegration, usually with the emission of one or more smaller particles from the *parent* nucleus, changing it into another, or daughter, nucleus. The parent nucleus is said to decay into the *daughter* nucleus.

The *daughter* may or may not be stable, and several successive decays may occur until a stable isotope is formed.

An example of radioactivity is



Radioactivity is *always* accompanied by a *decrease* in mass and is thus always exothermic. The energy liberated shows up as kinetic energy of the emitted particles and as  $\gamma$  radiation. The light particle is ejected at high speed, whereas the heavy one recoils at a much slower pace in an opposite direction.

Naturally occurring radio isotopes emit  $\alpha$ ,  $\beta$ , or  $\gamma$  particles or radiations. The artificial isotopes, in addition to the above, emit or undergo the following particles or reactions: positrons; orbital electron absorption, called K capture; and neutrons. In addition, neutrino emission accompanies  $\beta$  emission (of either sign).

**Alpha decay.** Alpha particles are helium nuclei, each consisting of two protons and two neutrons. They are commonly emitted by the heavier radioactive nuclei. An example is the decay of  $\text{Pu}_{239}$  into fissionable  $\text{U}_{235}$



**Beta decay.** An example of  $\beta$  decay is



where  $\bar{\nu}$ , the symbol for the neutrino, is often dropped from the equation. The penetrating power of  $\beta$  particles is small compared with that of  $\gamma$ -rays but is larger than that of  $\alpha$  particles.  $\beta^-$  and  $\beta^+$  decay are usually accompanied by the emission of  $\gamma$  radiation.

**Gamma radiation.** This is electromagnetic radiation of extremely short wavelength and very high frequency and therefore high energy.  $\gamma$ -rays and X-rays are physically similar but differ in their origin and energy:  $\gamma$ -rays from the nucleus, and X-rays from the atom because of orbital electrons changing

orbits or energy levels. Gamma wave-lengths are, on an average, about one-tenth those of X-rays, although the energy ranges overlap somewhat. Gamma decay does not alter either the atomic or mass numbers.

## 10.10 NUCLEAR REACTOR

### 10.10.1 PARTS OF A NUCLEAR REACTOR

A nuclear reactor is an apparatus in which heat is produced due to nuclear fission chain reaction.

Fig. 10.6 shows the various parts of reactor, which are as follows :

1. Nuclear Fuel
2. Moderator

3. Control Rods
4. Reflector
5. Reactors Vessel
6. Biological Shielding
7. Coolant.

Fig. 10.6 shows a schematic diagram of nuclear reactor.

r.

### 10.10.2 NUCLEAR FUEL

Fuel of a nuclear reactor should be fissionable material which can be defined as an element or isotope whose nuclei can be caused to undergo nuclear fission by nuclear bombardment and to produce a fission chain reaction. It can be one or all of the following

$U_{233}$ ,  $U_{235}$  and  $Pu_{239}$ .

Natural uranium found in earth crust contains three isotopes namely  $U_{234}$ ,  $U_{235}$  and  $U_{238}$  and their average percentage is as follows :

$U_{238}$  — 99.3%

$U_{235}$  — 0.7%

$U_{234}$  — Trace

Out of these  $U_{235}$  is most unstable and is capable of sustaining chain reaction and has been given the name as primary fuel.  $U_{233}$  and  $Pu_{239}$  are artificially produced from  $Th_{232}$  and  $U_{238}$  respectively and are called secondary fuel.

NUCLEAR POWER PLANT 323

$Pu_{239}$  and  $U_{233}$  so produced can be fissioned by thermal neutrons. Nuclear fuel should not be expensive to fabricate. It should be able to operate at high temperatures and should be resistant to radiation damage.

Uranium deposits are found in various countries such as Congo, Canada, U.S.A., U.S.S.R., Australia.

The fuel should be protected from corrosion and erosion of the coolant and for this it is encased in metal cladding generally stainless steel or aluminum. Adequate arrangements should be made for fuel supply, charging or discharging and storing of the fuel.

For economical operation of a nuclear power plant special attention should be paid to reprocess the spent: up (burnt) fuel elements and the unconsumed fuel. The spent up fuel elements are intensively radioactive and emits some neutron and gamma rays and should be handled carefully.

In order to prevent the contamination of the coolant by fission products, a protective coating or cladding must separate the fuel from the coolant stream. Fuel element cladding should possess the following properties :

1. It should be able to withstand high temperature within the reactor.
2. It should have high corrosion resistance.
3. It should have high thermal conductivity.
4. It should not have a tendency to absorb neutrons.
5. It should have sufficient strength to withstand the effect of radiations to which it is subjected.

Uranium oxide ( $UO_2$ ) is another important fuel element. Uranium oxide has the following advantages over natural uranium:

1. It is more stable than natural uranium.
2. There is no problem or phase change in case of uranium oxide and therefore it can be used for higher temperatures.
3. It does not corrode as easily as natural uranium.
4. It is more compatible with most of the coolants and is not attacked by  $H_2$ ,  $N_2$ .
5. There is greater dimensional stability during use.

Uranium oxide possesses following disadvantages :

1. It has low thermal conductivity.
2. It is more brittle than natural uranium and therefore it can break due to thermal stresses.
3. Its enrichment is essential.

Uranium oxide is a brittle ceramic produced as a powder and then sintered to form fuel pellets.

Another fuel used in the nuclear reactor is uranium carbide (UC). It is a black ceramic used in the form of pellets.

Table indicates some of the physical properties of nuclear fuels.

**Fuel Thermal con- Specific heat Density  $kg/m^3$  Melting point**

**ductivity K- kcal/kg °C (°C)**  
**cal/m. hr°C**

Natural uranium 26.3 0.037 19000 1130

Uranium oxide 1.8 0.078 11000 2750

Uranium carbide 20.6 — 13600 2350

324 POWER PLANT ENGINEERING

### **MODERATOR**

In the chain reaction the neutrons produced are fast moving neutrons. These fast moving neutrons are far less effective in causing the fission of U<sub>235</sub> and try to escape from the reactor. To improve the utilization of these neutrons their speed is reduced. It is done by colliding them with the nuclei of other material which is lighter, does not capture the neutrons but scatters them. Each such collision causes loss of

energy, and the speed of the fast moving neutrons is reduced. Such material is called Moderator. The slow neutrons (Thermal Neutrons) so produced are easily captured by the nuclear fuel and the chain reaction proceeds smoothly. Graphite, heavy water and beryllium are generally used as moderator.

Reactors using enriched uranium do not require moderator. But enriched uranium is costly due to processing needed.

A moderator should possess the following properties :

1. It should have high thermal conductivity.
2. It should be available in large quantities in pure form.
3. It should have high melting point in case of solid moderators and low melting point in case of liquid moderators. Solid moderators should also possess good strength and machinability.
4. It should provide good resistance to corrosion.
5. It should be stable under heat and radiation.
6. It should be able to slow down neutrons.

### **MODERATING RATIO**

To characterize a moderator it is best to use so called moderating ratio which is the ratio of moderating power to the macroscopic neutron capture coefficient. A high value of moderating ratio indicates

that the given substance is more suitable for slowing down the neutrons in a reactor. Table 10.3 indicates the moderating ratio for some of the material used as moderator.

#### **Material Moderating ratio**

Beryllium 160

Carbon 170

Heavy Water 12,000

Ordinary Water 72

This shows that heavy water, carbon and, beryllium are the best moderators

#### **Table 10.4**

##### **Moderator Density (gm/cm<sup>3</sup>)**

H<sub>2</sub>O 1

D<sub>2</sub>O 11

C 1.65

Be 1.85

Table 10.5 shows some of the physical constants of heavy water and ordinary water

NUCLEAR POWER PLANT 325

#### **Table 10.5**

##### **Physical constant D<sub>2</sub>O H<sub>2</sub>O**

Density at 293 K 1.1 gm/cm<sup>3</sup> 0.9982 gm/cm<sup>3</sup>

Freezing temperature 276.82 273

Boiling temperature 374.5 373 K

Dissociation Constant  $0.3 \times 10^{-14}$   $1 \times 10^{-14}$

Dielectric Constant at 293°K 80.5 82

Specific heat at 293°K 1.018 1

**Control Rods.** The Control and operation of a nuclear reactor is quite different from a fossil and fuelled (coal or oil fired) furnace. The furnace is fed continuously and the heat energy in the furnace is controlled by regulating the fuel feed, and the combustion air whereas a nuclear reactor contains as much fuel as is sufficient to operate a large power plant for some months. The consumption of this fuel

and the power level of the reactor depends upon its neutron flux in the reactor core. The energy produced in the reactor due to fission of nuclear fuel during chain reaction is so much that if it is not controlled properly the entire core and surrounding structure may melt and radioactive fission products may come out of the reactor thus making it uninhabitable. This implies that we should have some means to control the power of reactor. This is done by means of control rods.

Control rods in the cylindrical or sheet form are made of boron or cadmium. These rods can be moved in and out of the holes in the reactor core assembly. Their insertion absorbs more neutrons and damps down the reaction and their withdrawal absorbs less neutrons. Thus power of reaction is controlled by shifting control rods which may be done manually or automatically.

Control rods should possess the following properties :

1. They should have adequate heat transfer properties.
2. They should be stable under heat and radiation.
3. They should be corrosion resistant.
4. They should be sufficient strong and should be able to shut down the reactor almost instantly under all conditions.
5. They should have sufficient cross-sectional area for the absorption.

#### **10.10.5 REFLECTOR**

The neutrons produced during the fission process will be partly absorbed by the fuel rods, moderator, coolant or structural material etc. Neutrons left unabsorbed will try to leave the reactor core never to return to it and will be lost. Such losses should be minimized. It is done by surrounding the reactor core by a material called reflector which will send the neutrons back into the core. The returned neutrons can then cause more fission and improve the neutrons economy of the reactor. Generally the reflector is made up of graphite and beryllium.

#### **10.10.6 REACTOR VESSEL**

It is a strong walled container housing the core of the power reactor. It contains moderator, reflector, thermal shielding and control rods.

326 POWER PLANT ENGINEERING

#### **10.10.7 BIOLOGICAL SHIELDING**

Shielding the radioactive zones in the reactor to avoid possible radiation hazard is essential to protect the operating men from the harmful effects. During fission of nuclear fuel, alpha particles, beta particles, deadly gamma rays and neutrons are produced. Out of these neutrons and gamma rays are of main significance. A protection must be provided against them. Thick layers of lead or concrete are provided round the reactor for stopping the gamma rays. Thick layers of metals or plastics are sufficient to stop the alpha and beta particles.

#### **10.10.8 COOLANT**

Coolant flows through and around the reactor core. It is used to transfer the large amount of heat produced in the reactor due to fission of the nuclear fuel during chain reaction. The coolant either transfers its heat to another medium or if the coolant used is water it takes up the heat and gets converted into steam in the reactor which is directly sent to the turbine.

Coolant used should be stable under thermal condition. It should have a low melting point and high boiling point. It should not corrode the material with which it comes in contact. The coolant should have high heat transfer coefficient. The radioactivity induced in coolant by the neutrons bombardment should be nil. The various fluids used as coolant are water (light water or heavy water), gas (Air, CO<sub>2</sub>, Hydrogen, Helium) and liquid metals such as sodium or mixture of sodium and potassium and inorganic and organic fluids.

Power required to pump the coolant should be minimum. A coolant of greater density and higher specific heat demands less pumping power and water satisfies this condition to a great extent. Water is a good coolant as it is available in large quantities can be easily handled, provides some lubrication also and offers no unusual corrosion problems. But due to its low boiling point (212 F at atmospheric pressure) it is to be kept under high pressure to keep it in the liquid state to achieve a high heat transfer efficiency. Water when used as coolant should be free from impurities otherwise the impurities may become radioactive and handling of water will be difficult.

#### **10.10.9 COOLANT CYCLES**

The coolant while circulating through the reactor passages take up heat produced due to chain reaction and transfer this heat to the feed water in three ways as follows :

(a) *Direct Cycle*. In this system coolant which is water leaves the reactor in the form of steam.

Boiling water reactor uses this system.

(b) *Single Circuit System*. In this system the coolant transfers the heat to the feed water in the steam generator. This system is used in pressurized reactor.

(c) *Double Circuit System*. In this system two coolant are used. Primary coolant after circulating through the reactor flows through the intermediate heat exchanger (IHX) and passes on its heat to the secondary coolant which transfers its heat in the feed water in the steam generator. This system is used in sodium graphite reactor and fast breeder reactor.

#### **10.10.10 REACTOR CORE**

Reactor core consists of fuel rods, moderator and space through which the coolant flows.

NUCLEAR POWER PLANT 327

#### **10.11 CONSERVATION RATIO**

It is defined as the ratio of number of secondary fuel atoms to the number of consumed primary fuel atoms. A reactor with a conversion ratio above unity is known as a breeder reactor. Breeder reactor produces more fissionable material than it consumes. If the fissionable material produced is equal to or less than the consumed, the reactor is called converter reactor.

#### **10.12 NEUTRON FLUX**

It is a measure of the intensity of neutron radiation and it is the number of neutrons passing through 1 cm<sup>2</sup> of a given target in one second. It is expressed as  $uv$ , where  $u$  is number of neutrons per cubic centimeter and  $v$  is velocity of neutrons in cm/sec.

#### **10.13 CLASSIFICATION OF REACTORS**

The nuclear reactors can be classified as follows :

1. Neutron Energy. Depending upon the energy of the neutrons at the time they are captured by the fuel to induce fissions, the reactors can be named as follows :

(a) *Fast Reactors*. In such reactors fission is brought about by fast (non moderated) neutrons.

(b) *Thermal Reactors or Slow Reactors*. In these reactors the fast moving neutrons are slowed down by passing them through the moderator. These slow moving neutrons are then captured by the fuel material to bring about the fission of fundamental research.

#### **10.14 COST OF NUCLEAR POWER PLANT**

Nuclear power plant is economical if used as base load power plant and run at higher load factors.

The cost of nuclear power plant is more at low load factors. The overall running cost of a nuclear power plant of large capacity may be about 5 paisa per kWh but it may be as high 15 paisa per kWh if the plant is of smaller capacity. The capital cost of a nuclear power plant of larger capacity (say 250 mW) is nearly Rs. 2500 per kW installed. A typical sub-division of cost is as follows :

328 POWER PLANT ENGINEERING

##### **Item Approximate Cost %**

(a) Capital cost of land, building and 62% equipment etc.

(b) Fuel cost 22%

(c) Maintenance cost 6%

(d) Interest on capital cost 10%

The capital investment items include the following :

(i) Reactor Plant : (a) Reactor vessel, (b) Fuel and fuel handling system, (c) Shielding. (ii) Coolant system. (iii) Steam turbines, generators and the associated equipment. (iv) Cost of land and construction costs.

The initial investment and capital cost of a nuclear power plant is higher as compared to a thermal power plant. But the cost of transport and handling of coal for a thermal power plant is much higher than the cost of nuclear fuel. Keeping into view the depletion of fuel (coal, oil, gas) reserves and transportation

of such fuels over long distances, nuclear power plants can take an important place in the development of power potentials.

#### **NUCLEAR POWER STATION IN INDIA**

The various nuclear power stations in India are as follows :

(i) **Tarapur Nuclear Power Station**. It is India's first nuclear power plant. It has been built at Tarapur 60 miles north of Bombay with American collaboration. It has two boiling water reactors each of 200 mW capacity and uses enriched uranium as its fuel. It supplies power to Gujarat and Maharashtra. Tarapur power plant is moving towards the stage of using mixed oxide fuels as an alternative to uranium. This process involves recycling of the plutonium contained in the spent fuel. In the last couple



of years it has become necessary to limit the output of reactors to save the fuel cycle in view of the uncertainty of enriched uranium supplies from the United States.

(ii) **Rana Pratap Sagar (Rajasthan) Nuclear Station.** It has been built at 42 miles south west of Kota in Rajasthan with Canadian collaboration. It has two reactors each of 200 mW capacity and uses natural uranium in the form of oxide as fuel and heavy water as moderator.

(iii) **Kalpakkam Nuclear Power Station.** It is the third nuclear power station in India and is being built at about 40 miles from Madras City. It will be wholly designed and constructed by Indian scientists and engineers. It has two fast reactors each of 235 mW capacity and will use natural uranium as its fuel.

The first unit of 235 mW capacity has started generating power from 1983 and the second 235 MW unit is commissioned in 1985. The pressurized heavy water reactors will use natural uranium available in plenty in India. The two turbines and steam generators at the Kalpakkam atomic power project are the largest capacity generating sets installed in our country. In this power station about 88% local machinery and equipment have been used.

(iv) **Narora Nuclear Power Station.** It is India's fourth nuclear power station and is being built at Narora in Bullandshahar District of Uttar Pradesh. This plant will initially have two units of 235 mW each and provision has been made to expand its capacity of 500 mW. It is expected to be completed by 1991.

This plant will have two reactors of the CANDUPHW (Canadian Deutrium-Uranium-Pressurised Heavy Water) system and will use natural uranium as its fuel. This plant will be wholly designed and constructed by the Indian scientists and engineers. The two units are expected to be completed by 1989 and 1990 respectively. This plant will use heavy water as moderator and coolant. This plant will provide electricity at 90 paise per unit. Compared to the previous designs of Rajasthan and Madras nuclear power plants the design of this plant incorporates several improvements. This is said to be a major effort towards evolving a standardized design of 235 mW reactors and a stepping stone towards the design of 500 mW reactors. When fully commissioned plant's both units will provide 50 mW to Delhi, 30 mW to Haryana, 15 mW to Himachal Pradesh, 35 mW to Jammu and Kashmir, 55 mW to Punjab, 45 mW to Rajasthan, 165 mW to Uttar Pradesh and 5 mW to Chandigarh. The distribution of remaining power will depend on the consumer's demands. In this plant one exclusion zone of 1.6 km radius has been provided where no public habitation is permitted. Moderate seismicity alluvial soil conditions in the region of Narora have been fully taken into account in the design of the structure systems and equipment in Narora power plant.

Narora stands as an example of a well coordinated work with important contributions from Bhabha Atomic Research Centre, Heavy Water Board, Nuclear Fuel Complex, Electronics Corporation of India Limited (ECIL) and other units of Department of Atomic Energy and several private and public sector industries Instrumentation and control systems are supplied by ECIL. Bharat Heavy Electrical Limited (BHEL) is actively associated with Nuclear Power Corporation of India. It has supplied steam generators, reactor headers and heat exchangers for Narora Atomic Power Plant (NAPP) 1 and 2 (2 × 235 MW).

NAPP is the forerunner of a whole new generation of nuclear power plants that will come into operation in the next decade. The design of this reactor incorporates several new safety features ushering in the state of the art in reactor technology. The design also incorporates two fast acting and independent reactor shut down systems conceptually different from those of RAPP and MAPP.

Some of the new systems introduced are as follows :

1. Emergency Core Cooling System (ECCS).
2. Double Containment System.
3. Primary Shut off rod System (PSS).
4. Secondary Shut off rod System (SSS).
5. Automatic Liquid Poison Addition System (ALPAS).
6. Post accident clean up system.

According to Department of Atomic Energy (DAE) the Narora Atomic Power Plant (NAPP) has the following features.

1. It does not pose safety and environmental problems for the people living in its vicinity. The safety measures are constantly reviewed to ensure that at all times radiation exposure is well within limits not only to the plant personnel but also to the public at large.
2. NAI'P design meets all the requirement laid down in the revised safety standards. The design of power plant incorporates two independent fast acting shut down systems high pressure,



intermediate pressure and low pressure emergency core cooling systems to meet short and long term requirements and double containment of the reactor building.

330 POWER PLANT ENGINEERING

Narora Atomic Power Plant (NAPP) is pressurized heavy water reactor (PHWR) that has been provided with double containment. The inner containment is of pre-stressed concrete designed to withstand the full pressure of 1.25 kg/cm<sup>2</sup> that is likely to be experienced in the event of an accident. The outer containment is of reinforced cement concrete capable of withstanding the pressure of 0.07 kg/cm<sup>2</sup>. The angular space between the two containments is normally maintained at a pressure below atmosphere to ensure that any activity that might leak past primary containment is vented out through the stack and not allowed to come out to the environment in the immediate vicinity of the reactor building. The primary and the secondary containments are provided with highly efficient filtration systems which filter out the active fission products before any venting is done.

The moment containment gets pressurized it gets totally sealed from the environment. Subsequently the pressure in the primary containment is brought down with the help of the following provisions.

1. Pressure suppression pool at the basement of the reactor building.
2. Special cooling fan units which are operated on electrical power obtainable from emergency diesel generators. The containment provisions are proof tested to establish that they are capable of withstanding the pressures that are expected in the case of an accident. Fig. 5.12 (a) shows primary and secondary containment arrangement.
3. The cooling water to all the heavy water heat exchangers is maintained in a closed loop so that failure in these do not lead to escape of radioactivity very little water from River (Ganga) would be drawn for cooling purposes and most of water would be recycled.
4. The power plant has a waste management plant and waste burial facility within the plant area.
5. NAPP is the first pressurized heavy water reactor (PHWR) in the world to have been provided with double containment.
6. No radioactive effluent, treated or otherwise will be discharged into Ganga River. Therefore there will be no danger of pollution of the Ganga water.
7. An exclusion zone of 1.6 km radius around the plant has been provided where no habitation is permitted.
8. A comprehensive fire fighting system on par with any modern power station has been provided at NAPP.
9. NAPP has safe foundations. It is located on the banks of river Ganges an alluvial soil. The foundations of the plant reach upto a depth where high relative densities and bearing capacities are met. The foundations design can cater to all requirements envisaged during life of plant.) It is safe against earthquakes.
10. In the event of danger over heated core of the reactor would be diffused with in a few seconds by two features namely shut down through control rods followed by injection of boron rich water which will absorb the neutrons and stop their reaction in the core. This is in addition to other feature like double containment system provided in the reactor.

Above features assure total radiation safety of the plant personnel, general public and the environment during the operation of power plant. With the completion of NAPP it would make a useful contribution to the North-grid thereby accelerating the pace of development in this region.

Narora Atomic Power Plant is the fourth atomic power plant to be commissioned in India. This power plant is meant to generate electricity and supply the same to the distribution system (grid) in Uttar Pradesh and other states in the northern region. It has two units each with a capacity of 235 mW of which about seven per cent will be used to run the in house equipment and the rest will be fed into the grid. The net output from the power plant will be about 435 mW. At this power plant all due precautions have been taken in the design, construction, commissioning and operation of the unit with safety as the over-riding consideration. Therefore there appears to be no danger to the public from the operation of this power plant.

(v) **Kakarpar Nuclear Power Plant.** This fifth nuclear power plant of India is to be located at Kakarpar near Surat in Gujarat. This power station will have four reactors each of 235 mW capacity. The reactors proposed to be constructed at Kakarpar would be of the Candu type natural uranium

fuelled and heavy water moderated reactors-incorporating the standardised basic design features of the Narora reactors suitably adapted to local conditions. The fuel for the power plant will be fabricated at the Nuclear Fuel complex, Hyderabad. The power plant is expected to be completed by 1991.

The Kakrapur unit has two fast shut down systems. The primary one works by cadmium shut off rods at 14 locations which drop down in case of heat build up and render the reactor sub-critical in two seconds. There are 12 liquid shut off rods as a back up, further backed by slow acting automatic liquid poison addition system which absorbs neutrons completely and stop the fissile reaction.

In case of sudden loss of coolant, heavy water inside the reactor, there is an emergency core cooling system which also stops the fissile reaction. Lastly, the pressure suppression system in which cool water under the reactor rises automatically to reduce pressure in case it increases and a double containment wall ensures that no radioactivity would be released at ground level even in case of an unlikely accident.

The Department of Atomic Energy (DAE) has also evolved emergency preparedness plans for meeting any accident even after all these safety measures. It ensures a high level of preparedness to face an accident including protecting the plant personnel and surrounding population. There is no human settlement for five km belt around a nuclear power installation as a mandatory provision.

(vi) **Kaiga Atomic Power Plant.** The sixth atomic power plant will be located at Kaiga in Karnataka. Kaiga is located away from human habitation and is a well suited site for an atomic power plant. It will have two units of 235 mW each. It is expected to be commissioned by 1995. This nuclear power plant will have CANDU type reactors. These reactors have modern systems to prevent accidents. The plant would have two solid containment walls-inner and outer to guard against any leakage. The inner containment wall could withstand a pressure of 1.7 kg/cm<sup>2</sup> and could prevent the plant from bursting. The outer containment walls of the reinforced cement concrete has been design to withstand pressure of 0.07 kg/cm<sup>2</sup>. The annular space between the two containment walls would be maintained at a lower pressure below that of the atmosphere to ensure that no radioactivity leaked past the primary containments.

## **10.16 LIGHT WATER REACTORS (LWR) AND HEAVY WATER REACTORS (HWR)**

Light water reactors use ordinary water (technically known as light water) as coolant and moderator. They are simpler and cheaper. But they require enriched uranium as their fuel. Natural uranium contains 0.6% of fissionable isotope U<sup>235</sup> and 99.3% of fertile Lj<sup>23</sup> and to use natural uranium in such

332 POWER PLANT ENGINEERING

reactors it is to be enriched to about 3%, U<sup>235</sup> and for this uranium enrichment plant is needed which requires huge investment and high operational expenditure. Heavy water reactors use heavy water as their coolant and moderator. They have the advantage of using natural uranium as their fuel. Such reactors have some operation problem too. Heavy water preparation plants require sufficient investment and leakage of heavy water must be avoided as heavy water is very costly. Heavy water required in primary circuits must be 99% pure and this requires purification plants heavy water should not absorb moisture as by absorbing moisture it gets degraded. In order to have sufficient quantity of heavy water required for nuclear power plants, the work is fast progressing in our country on four heavy water plant. These plants are situated at Kotah (100 tonnes per year), Baroda (67.2 tonnes), Tuticorin (71.3 tonnes) and Talcher (67.2 tonnes per year). These plants will give our country an installed heavy water production capacity of about 300 tonnes per year.

### **10.16.1 Importance of Heavy Water**

The nuclear power plants of Kota in Rajasthan, Kalpakkam in Tamil Nadu and Narora in U.P. use heavy water as coolant and moderator. All these projects have CANDU reactors using natural uranium as fuel and heavy water as moderator. After this enriched uranium natural water reactor at Tarapur, the CANDU reactors are the second generation of reactors in India's nuclear power programme. The CANDU reactor will produce plutonium which will be the core fuel for fast breeder reactor. In fact in breeder reactor heavy water is used as moderator.

A CANDU reactor of 200 mW capacity requires about 220 tonnes of heavy water in the initial stages and about 18 to 24 tonnes each year subsequently. Therefore, about one thousand tonnes of heavy water will be required to start the different nuclear power stations using heavy water. The total capacity of different heavy water plants will be about 300 tonnes per year if all the heavy water plant under construction start production. It is expected that heavy water from domestic production will be available from Madras and Narora atomic power plants. The management of the heavy water system is a highly complicated affair and requires utmost caution. Heavy water is present in ordinary water in the ratio 1 :

6000. One of the methods of obtaining heavy water is electrolysis of ordinary water.

### **ADVANTAGES OF NUCLEAR POWER PLANT**

The various advantages of a nuclear power plant are as follows:

1. Space requirement of a nuclear power plant is less as compared to other conventional power plants are of equal size.
2. A nuclear power plant consumes very small quantity of fuel. Thus fuel transportation cost is less and large fuel storage facilities are not needed Further the nuclear power plants will conserve the fossil fuels (coal, oil, gas etc.) for other energy need.
3. There is increased reliability of operation.
4. Nuclear power plants are not effected by adverse weather conditions.
5. Nuclear power plants are well suited to meet large power demands. They give better performance at higher load factors (80 to 90%).
6. Materials expenditure on metal structures, piping, storage mechanisms are much lower for a nuclear power plant than a coal burning power plant.  
For example for a 100 mW nuclear power plant the weight of machines and mechanisms, weight of metal structures, weight of pipes and fittings and weight of masonry and bricking up required are nearly 700 tonnes, 900 tonnes, 200 tonnes and 500 tonnes respectively whereas for a 100 mW coal burning power plant the corresponding value are 2700 tonnes, 1250 tonnes, 300 tonnes and 1500 tonnes respectively. Further area of construction site required aired for 100 mW nuclear power plant is 5 hectares whereas was for a 100 mW coal burning power plant the area of construction site is nearly 15 hectares.
7. It does not require large quantity of water.

### **DISADVANTAGES**

1. Initial cost of nuclear power plant is higher as compared to hydro or steam power plant.
2. Nuclear power plants are not well suited for varying load conditions.
3. Radioactive wastes if not disposed carefully may have bad effect on the health of workers and other population.  
In a nuclear power plant the major problem faced is the disposal of highly radioactive waste in form of liquid, solid and gas without any injury to the atmosphere. The preservation of waste for a long time creates lot of difficulties and requires huge capital.
4. Maintenance cost of the plant is high.
5. It requires trained personnel to handle nuclear power plants.

### **SITE SELECTION**

The various factors to be considered while selecting the site for nuclear plant are as follows :

- 1. Availability of water.** At the power plant site an ample quantity of water should be available for condenser cooling and made up water required for steam generation. Therefore the site should be nearer to a river, reservoir or sea.
- 2. Distance from load center.** The plant should be located near the load center. This will minimise the power losses in transmission lines.
- 3. Distance from populated area.** The power plant should be located far away from populated area to avoid the radioactive hazard.
- 4. Accessibility to site.** The power plant should have rail and road transportation facilities.
- 5. Waste disposal.** The wastes of a nuclear power plant are radioactive and there should be sufficient space near the plant site for the disposal of wastes.
- Safeguard against earthquakes.** The site is classified into its respective seismic zone 1, 2, 3, 4, or 6. The zone 5 being the most seismic and unsuitable for nuclear power plants. About 300 km of radius area around the proposed site is studied for its past history of tremors, and earthquakes to assess the severest earthquake that could occur for which the foundation building and equipment supports are designed accordingly. This ensures that the plant will retain integrity of structure, piping and equipments should an earthquake occur. The site selected should also take into account the external natural events such as floods, including those by up-stream dam failures and tropical cyclones.  
The most important consideration in selecting a site for a nuclear power plant is to ensure that the site-plant combination does not pose radio logical or any hazards to either the public, plant personnel on the environment during normal operation of plant or in the unlikely event of an accident.  
The Atomic Energy Regulatory Board (AERB) has stipulated a code of practice on safety in

Nuclear Power Plant site and several safety guide lines for implementation.

334 POWER PLANT ENGINEERING

## 10.18 COMPARISON OF NUCLEAR POWER PLANT AND STEAM POWER PLANT

The cost of electricity generation is nearly equal in both these power plants. The other advantages and disadvantages are as follows :

- (i) The number of workman required for the operation of nuclear power plant is much less than a steam power plant. This reduces the cost of operation.
- (ii) The capital cost of nuclear power plant falls sharply if the size of plant is increased. The capital cost as structural materials, piping, storage mechanism etc. much less in nuclear power plant than similar expenditure of steam power plant. However, the expenditure of nuclear reactor and building complex is much higher.
- (iii) The cost of power generation by nuclear power plant becomes competitive with cost of steam power plant above the unit size of about 500 mW.

## 10.19 MULTIPLICATION FACTOR

Multiplication factor is used to determine whether the chain reaction will continue at a steady rate, increase or decrease. It is given by the relation,

$$K =$$

$$\left( \frac{P}{A + E} \right)$$

$$P$$

$$A + E$$

where  $K$  = Effective multiplication factor.

$P$  = Rate of production of neutrons.

$A$  = Combined rate of absorption of neutrons.

$E$  = Rate of leakage of neutrons.

$K = 1$  indicates that the chain reaction will continue at steady rate (critical)  $K > 1$  indicates that the chain reaction will be building up

(super critical) whereas  $K < 1$  shows that reaction will be dying down (subcritical).

## 10.20 URANIUM ENRICHMENT

In some cases the reaction does not take place with natural uranium containing only 0.71% of  $U_{235}$ .

In such cases it becomes essential to use uranium containing higher content of  $U_{235}$ . This is called  $U_{235}$  concentration of uranium enrichment. The various methods of uranium enrichment are as

**1. The gaseous diffusion method.** This method is based on the principle that the diffusion or penetration molecular of a gas with a given molecular weight through a porous barrier is quicker than the molecules of a heavier gas. Non-saturated uranium hexa-flouride ( $UF_6$ ) is used for gaseous diffusion. The diffusing molecules have small difference in mass. The molecular weight of  $U_{235}Fs = 235 + 6 \times 19 = 349$  and that  $U_{238}Fs = 352$ . The initial mixture is fed into the gap between the porous barrier. That part of the material which passes through the barrier is enriched product, enriched in  $U_{235}Fs$  molecules and the remainder is depleted product.

NUCLEAR POWER PLANT 335

**2. Thermal diffusion method.** In this method (Fig. 10.9) a column consisting of two concentric pipes is used. Liquid  $UF_6$  is filled in the space between the two pipes. Temperature of one of the pipes is kept high and that of other is kept low. Due to difference in temperature the circulation of the liquid starts, the liquid rising along the hot wall and falling along the cold wall. Thermal diffusion takes place in the column. The light  $U_{235}Fs$  molecules are concentrated at the hot wall and high concentration of  $U_{236}Fs$  is obtained in the upper part of the column.

**3. Electromagnetic Method.** This method is based on the fact that when ions moving at equal velocities along a straight line in the same direction are passed through a magnetic field, they are acted upon by forces perpendicular to the direction of ion movement and the field.

Let  $P$  = force acting on ion  $e$  = charge on ion

$v$  = velocity of ion

$H$  = magnetic field strength  $m$  = Ion mass

$R$  = radius of ion path  $P = euH$

As this force is centripetal

$$4 P =$$

$$\begin{aligned}
&mv^2 \\
&R \\
&4 \\
&mv^2 \\
&R \\
&= e\nu H \\
&4 R = \\
&mv \\
&eH
\end{aligned}$$

This shows that ions moving at equal velocities but different masses move along different circumferences of different radii (Fig. 10.10). Fig. 10.11 shows an electromagnetic separation unit for uranium isotopes. A gaseous uranium compound is fed into the ion source, where neutral atoms are ionised with the help of ion bombardment. The ions produced come out in the form of narrow beam after passing through a number of slits. This beam enters the acceleration chamber. These ions then enter a separation chamber where a magnetic field is applied. Due to this magnetic field the ions of different masses move along different circumferences.

**4. Centrifugation Method,** This method is based on the fact that when a mixture of two gases with different molecular weight is made to move at a high speed in a centrifuge, the heavier gas is obtained near the periphery. UF<sub>6</sub> vapour may be filled in the centrifuge and rotated to separate uranium isotopes.

## REACTOR POWER CONTROL

The power released in a nuclear reactor is proportional to the number of mole fissioned per unit time this number being in turn proportional to density of the neutron flux in the reactor. The power of a nuclear reactor can be controlled by shifting control rods which may be either actuated manually or automatically.

Power control of a nuclear reactor is simpler than that of conventional thermal power plant because power of a nuclear reactor is a function of only one variable whereas power of a thermal power plant depends on number of factors such as amount of fuel, its moisture content, air supply etc. This shows that power control of thermal plant requires measuring and regulating several quantities which is of course considerably more complicated.

## NUCLEAR POWER PLANT ECONOMICS

Major factors governing the role of nuclear power are its economic development and availability of sufficient amount of nuclear fuel.

It is important to extract as much energy from a given amount of fuel as possible. The electrical energy extracted per unit of amount of fuel or expensive moderator might be called the "material efficiency".

In a chain reactor the high material efficiency as well as high thermal efficiency leads to low over all energy cost.

Since the most attractive aspect of nuclear energy is the possibility of achieving fuel costs considerably below that for coal, all nuclear power system being considered for large scale power production involve breeding or regenerative systems. This program includes the development of the technology of low neutron absorbing structural materials such as zirconium, the use of special moderating materials such as D<sub>2</sub>O and the consideration of special problems associated with fast reactors. In so far as economic factors are concerned it is necessary to consider neutron economy in a general way such as that measured by the conversion ratio of the system. The conversion ratio is defined as the atoms of new

NUCLEAR POWER PLANT 337

fuel produced in fertile material per atom of fuel burnt. The conversion ratio varies with the reactor design. Its values for different reactors are indicated in table.

### Type of reactor Conversion ratio

BWR, PWR and SGR 1

Aqueous thorium breeder 1.2

## SAFETY MEASURES FOR NUCLEAR POWER PLANTS

Nuclear power plants should be located far away from the populated area to avoid the radioactive hazard. A nuclear reactor produces  $\alpha$  and  $\beta$  particles, neutrons and  $\gamma$ -quanta which can disturb the



normal functioning of living organisms. Nuclear power plants involve radiation leaks, health hazard to workers and community, and negative effect on surrounding forests.

At nuclear power plants there are three main sources of radioactive contamination of air.

(i) Fission of nuclei of nuclear fuels.

(ii) The second source is due to the effect of neutron fluxes on the heat carrier in the primary cooling system and on the ambient air.

(iii) Third source of air contamination is damage of shells of fuel elements.

This calls for special safety measures for a nuclear power plant. Some of the safety measures are as follows.

(i) Nuclear power plant should be located away from human habitation.

(ii) Quality of construction should be of required standards.

(iii) Waste water from nuclear power plant should be purified. The water purification plants must have a high efficiency of water purification and satisfy rigid requirements as regards the volume of radioactive wastes disposed to burial.

(iv) An atomic power plant should have an extensive ventilation system. The main purpose of this ventilation system is to maintain the concentration of all radioactive impurities in the air below the permissible concentrations.

(v) An exclusion zone of 1.6 km radius around the plant should be provided where no public habitation is permitted.

(vi) The safety system of the plant should be such as to enable safe shut down of the reactor whenever required. Engineered safety features are built into the station so that during normal operation as well as during a severe design basis accident the radiation dose at the exclusion zone boundary will be within permissible limits as per internationally accepted values. Adoption of a integral reactor vessel and end shield assemblies, two independent shut down systems, a high pressure emergency core cooling injection system and total double containment with suppression pool are some of the significant design improvements made in Narora Atomic Power Project (NAPP) design. With double containment NAPP will be able to withstand seismic shocks.

338 POWER PLANT ENGINEERING

In our country right from the beginning of nuclear power programme envisaged by our great pioneer Homi Bhabha in peaceful uses of nuclear energy have adopted safety measures of using double containment and moderation by heavy water one of the safest moderators of the nuclear reactors.

(vii) Periodical checks be carried out to check that there is no increase in radioactivity than permissible in the environment.

(viii) Wastes from nuclear power plant should be carefully disposed off. There should be no danger of pollution of water of river or sea where the wastes are disposed.

In nuclear power plant design, construction, commissioning and operation are carried out as per international and national codes of protection with an overriding place given to regulatory processes and safety of plant operating personnel, public and environment.

## **SITE SELECTION AND COMMISSIONING PROCEDURE**

In order to study prospective sites for a nuclear power plant the Department of Atomic Energy (DAE) of our country appoints a site selection committee with experts from the following:

1. Central Electricity Authority (CEA).
2. Atomic Minerals Division (AMD).
3. Health and safety group and the Reactor Safety Review group of the Bhabha Atomic Research Center (BARC).
4. Nuclear Power Corporation (NPC).

The committee carries out the study of sites proposed. The sites are then visited, assessed and ranked. The recommendations of the committee are then forwarded to DAE and the Atomic Energy Commission (AEC) for final selection.

The trend is to locate a number of units in a cluster at a selected site. The highest rated units in India are presently of 500 mW. The radiation dose at any site should not exceed 100 milligram per member of the public at 1.6 km boundary.

The commissioning process involves testing and making operational individually as well as in an integrated manner the various systems such as electrical service water, heavy water, reactor regulating and protection, steam turbine and generator. To meet the performance criteria including safe radiation



levels in the plant area and radioactive effluents during operation the stage-wise clearance from Atomic Energy Regulatory Board (AERB) is mandatory before filling heavy water, loading fuel making the reactor critical, raising steam, synchronizing and reaching levels of 25%, 50%, 75% and 100% of full power. The commissioning period lasts for about two years.

## **10.25 MAJOR NUCLEAR POWER DISASTERS**

**Chernobyl** — is near Kiev, Ukraine, in the former Soviet Union. Destroyed by steam and hydrogen explosions followed by fire, it caused many deaths on site, increased cancer rates in the thousands of square miles it contaminated.

**Three Mile Island** — Located 10 miles southeast of Harrisburg PA on the Susquehanna River. The accident, and radiation release, caused no immediate deaths. The cleanup cost more than \$1.5 Billion.

NUCLEAR POWER PLANT 339

The Three Mile Island accident occurred in 1979 and 1986, Chernobyl occurred essentially killing the expansion of nuclear energy. No other nuclear power plants have been ordered in the US since the late 1970's.

### **T.M.I. Account Chronology in Brief**

1970's AEC LOFT (Loss of Fluid Test) research canceled as economy measure.

September 12, 1978 T.M.I. Unit #2 dedicated.

January 1979 TMI #2 began commercial operation.

March 26, 1979 Emergency core cooling pumps tested, with diverter valves switched to disconnect ECCS from reactor. Valves not switched back.

March 28, 1979, 4 a.m. Three Mile Island Incident began.

—Filter in inner loop switched offline to clean

—Pressure transient triggers shutdown sequence.

—Core overheats, pressure relief valve sticks open, in manual override

—Water in core begins leaking out open relief valve

—Emergency cooling pumps don't work !

—After more errors, 1/3 of core exposed, partial meltdown of fuel rods results.

—2nd day someone closes relief valve (unrecorded).. situation stabilizes

—hydrogen gas bubble forms.

—Governor/NRC, order partial evacuation

Cleanup/termination cost \$1.5+ BILLION.

**Cleanup after the Three Mile Island Accident.** After the Accident it was necessary to dispose of the radioactive gases, water, and contaminated debris from radioactive plumbing etc. The water had to be filtered to separate and concentrate radioactive contaminants for disposal. After these were removed it was possible to begin dismantling the pressure vessel and extract the fuel rods. It was not until then that the inside of the core could be inspected. As the damaged reactor was brought under control, it was known from radiation monitoring that there was a significant amount of radioactive material in the bottom of the pressure vessel. In spite of this, the power company still maintained that the damage to the core had been minimal. When a robot with a video camera was lowered into the pressure vessel, four years after the accident, this is what it saw:

## **10.26 CHERNOBYL NUCLEAR POWER PLANT**

Chernobyl is a town of 30,000 people, 70 miles north of Kiev, in the Ukraine. The V. I. Lenin nuclear power plant is located 10 miles from the town of Chernobyl. Adjacent to the plant is the town of Pripyat, which houses and services plant workers. The plant is on the Pripyat River, near its mouth into the Kiev reservoir.

The plant had 4 nuclear reactors, each with associated steam turbines and electric generators.

Two additional units were under construction at the time of the accident, April 26, 1986. Each of these units was of the same Soviet design, designated RBMK-1000.

Chernobyl was the location of the world's worst nuclear power plant disaster. Massive amounts of radioactivity were released, a thousand square mile area will be uninhabitable for many decades.

340 POWER PLANT ENGINEERING

### **10.26.1 REACTOR DESIGN : RBMK-1000**

#### **Boiling Water Reactor**

Electric generating capacity 1000 Megawatt.

Thermal output of core about 2000 Megawatt.

1661 zirconium fuel rods, holding mix of U-238 and U-235; Plutonium-239 is a byproduct,

which can be extracted by reprocessing the fuel rod material. Each fuel rod is enclosed in a heat transfer water channel.

211 Boron control rods with 8 fuel rods/control rod

Graphite core 1700 tons, made up of graphite bricks

### **10.26.2 CONTROL OF THE REACTOR**

1. Graphite Core, moderates neutron flux from fuel rods
2. Boron control rods to reduce neutron flux for shutdown
3. Thermal transfer control — closed circuit water/steam loop, multiple water pumps Nitrogen/ Helium gas within containment — low thermal conductivity and oxygen exclusion — pressure and gas mixture are controlled. emergency core cooling water system (ECCS)

### **10.26.3 CHERNOBYL REACTOR OPERATIONS**

Computer for fine control, operator controls set points of feedback controllers Central power authority dictated operating levels in managing power grid Unnecessary shutdown meant 600,000 ruble revenue loss, firing of person responsible.

Plant engineers found the plant unstable at low power levels,

Local practice was to manually pull control rods if downward fluctuation threatened spontaneous shutdown. Response time to scram: 18 seconds (theoretically it was claimed to be 3 seconds).

Regulations against manual control routinely excepted.

### **10.26.4 ACCIDENT\SAFETY PLANS**

Published odds million to 1 against an accident. Authoritarian control staff & engineers do not question safety. Accident planning was around a scenario of 1 or 2 fuel rod/water channels bursting. No plan included a graphite fire. Administration building had emergency bunker under it. Reactor building was a water tight containment building.

### **10.26.5 EVACUATION**

Plant director had authority in principle to order evacuation of Pripjat. However a standing order made any nuclear accident a state secret.

## **10.27 SAFETY PROBLEMS IN CHERNOBYL REACTOR DESIGN**

### **10.27.1 SYSTEM DYNAMICS**

A problem with RMBK-1000 reactor design is that the time constants for changes in thermal output are short. Control depends on computer regulated feedback control systems. The human operator could not react fast enough to manually control it without the automatic controls.

NUCLEAR POWER PLANT 341

Neutron absorption and heat transfer coefficients are very different for water and steam, so neutron flux and thermal output changes rapidly as water in the tubes through the core makes a transition from hot water to steam.

### **10.27.2 ANOTHER SAFETY PROBLEM WITH THE DESIGN**

The normal operating temperature of core tubes is greater than the ignition temperature of the graphite blocks of the core (carbon) in an O<sub>2</sub> atmosphere. Its normal environment is an atmosphere with no oxygen.

#### **Heat exchange system :**

One closed loop through reactor core and steam turbines

Secondary loop to condense steam to water after turbine

#### **Construction problems :**

Turbine building roof; specification said it should be fireproof. Materials for 1 km × 50 m fireproof roof was not available. Control cable conduits supposed to be fireproof. Material not available.

Exception granted. Cement and tiles, etc. Quality control problems. Director had to prioritize uses, discard defective materials. Fittings often required remanufacture to meet specifications.

*Hazard Potential of Water on Hot Graphite*

Water Gas Reaction:



Often used as a H<sub>2</sub> generator in freshman chemistry labs, it has a similar hazard if not carefully controlled:

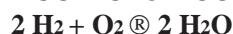

## **OTHER, EARLIER, SOVIET NUCLEAR ACCIDENTS**

September 1982 — Chernobyl Unit 1, after 5 years service, was shut down for maintenance.

Restarted with some valves closed. Result: no water flow in a few channels. Explosion in core, a few fuel rods melted. Some radioactivity escaped plant. No radiation survey was done outside plant. Streets of Pripyat were hosed down. No announcement to population. Emergency core cooling system saved plant. Chief Engineer, his deputy, and chief operator of the shift were all demoted and transferred.

1980 Kursh power station. RBMK-1000 plant had a power outage.

Reactor damaged because control rods and circulation driven by electric motors/pumps failed.

Time delay to start diesel generators was 40 seconds During which, power surge damaged some fuel rods. Solution : design a special generator to tap turbine power as it spun down during shutdown, to power emergency equipment.

Oct. 1982. Armyansk nuclear power station. Explosion. Subsequent fire destroyed turbine building.

Fall 1983 Chernobyl Unit 4 startup. Certification team saw anomalous power surge when control rod insertion starts. Considered minor, had been seen in another reactor. No explanation, not documented.

June 1985 Balakovsky PWR power station, Valve burst, release of 300 degree C. steam, cooked 14 workmen. Safety regulations viewed as guidelines, chief engineer regularly made exceptions.

# ***MODULE-III***

## ***Power Plant Economics and Variable Load Problem***

The main terms and factors are as follows:

### **1. Load Factor**

It is defined as the ratio of the average load to the peak load during a certain prescribed period of time. The load factor of a power plant should be high so that the total capacity of the plant is utilized for the maximum period that will result in lower cost of the electricity being generated. It is always less than unity. High load factor is a desirable quality. Higher load factor means greater average load, resulting in greater number of power units generated for a given maximum demand. Thus, the fixed cost, which is proportional to the maximum demand, can be distributed over a greater number of units (kWh) supplied. This will lower the overall cost of the supply of electric energy.

### **2. Utility Factor**

It is the ratio of the units of electricity generated per year to the capacity of the plant installed in the station. It can also be defined as the ratio of maximum demand of a plant to the rated capacity of the plant. Supposing the rated capacity of a plant is 200 mW. The maximum load on the plant is 100 mW at load factor of 80 per cent, then the utility will be  
$$= (100 \times 0.8)/(200) = 40\%$$

### **3. Plant Operating Factor**

It is the ratio of the duration during which the plant is in actual service, to the total duration of the period of time considered.

### **4. Plant Capacity Factor**

It is the ratio of the average loads on a machine or equipment to the rating of the machine or equipment, for a certain period of time considered.

Since the load and diversity factors are not involved with 'reserve capacity' of the power plant, a factor is needed which will measure the reserve, likewise the degree of utilization of the installed equipment.

For this, the factor "Plant factor, Capacity factor or Plant Capacity factor" is defined as,  
Plant Capacity Factor = (Actual kWh Produced)/(Maximum Possible Energy that might have produced during the same period)

Thus, the annual plant capacity factor will be,

$$= (\text{Annual kWh produced})/[\text{Plant capacity (kW)} \times \text{hours of the year}]$$

The difference between load and capacity factors is an indication of reserve capacity.

### **5. Demand Factor**

The actual maximum demand of a consumer is always less than his connected load since all the appliances in his residence will not be in operation at the same time or to their fullest extent. This ratio of the maximum demand of a system to its connected load is termed as demand factor. It is always less than unity.

### **6. Diversity Factor**

Supposing there is a group of consumers. It is known from experience that the maximum demands of the individual consumers will not occur at one time. The ratio of the sum of the individual maximum demands to the maximum demand of the total group is known as diversity factor. It is always greater than unity.

High diversity factor (which is always greater than unity) is also a desirable quality. With a given

number of consumers, higher the value of diversity factor, lower will be the maximum demand on the plant, since,

Diversity factor =  $\frac{\text{Sum of the individual maximum Demands}}{\text{Maximum demand of the total group}}$

So, the capacity of the plant will be smaller, resulting in fixed charges.

### **7. Load Curve**

It is a curve showing the variation of power with time. It shows the value of a specific load for each unit of the period covered. The unit of time considered may be hour, days, weeks, months or years.

### **8. Load Duration Curve**

It is the curve for a plant showing the total time within a specified period, during which the load equaled or exceeded the values shown.

### **9. Dump Power**

This term is used in hydro plants and it shows the power in excess of the load requirements and it is made available by surplus water.

### **10. Firm Power**

It is the power, which should always be available even under emergency conditions.

### **11. Prime Power**

It is power, may be mechanical, hydraulic or thermal that is always available for conversion into electric power.

### **12. Cold Reserve**

It is that reserve generating capacity which is not in operation but can be made available for service.

122 POWER PLANT ENGINEERING

### **13. Hot Reserve**

It is that reserve generating capacity which is in operation but not in service.

### **14. Spinning Reserve**

It is that reserve generating capacity which is connected to the bus and is ready to take the load.

### **15. Plant Use Factor**

This is a modification of Plant Capacity factor in that only the actual number of hours that the plant was in operation is used. Thus Annual Plant Use factor is,

=  $\frac{\text{Annual kWh produced}}{[\text{Plant capacity (kW)} \times \text{number of hours of plant operation}]}$

## **3.2 FACTOR EFFECTING POWER PLANT DESIGN**

Following are the factor effecting while designing a power plant.

- (1) Location of power plant
- (2) Availability of water in power plant
- (3) Availability of labour nearer to power plant
- (4) Land cost of power plant
- (5) Low operating cost
- (6) Low maintenance cost
- (7) Low cost of energy generation
- (8) Low capital cost

## **3.3 EFFECT OF POWER PLANT TYPE ON COSTS**

The cost of a power plant depends upon, when a new power plant is to set up or an existing plant is to be replaced or plant to be extended. The cost analysis includes

### **1. Fixed Cost**

It includes Initial cost of the plant, Rate of interest, Depreciation cost, Taxes, and Insurance.

### **2. Operational Cost**

It includes Fuel cost, Operating labour cost, Maintenance cost, Supplies, Supervision, Operating taxes.

### **3.3.1 INITIAL COST**

The initial cost of a power station includes the following:

1. Land cost
2. Building cost
3. Equipment cost
4. Installation cost

5. Overhead charges, which will include the transportation cost, stores and storekeeping charges, interest during construction etc.

POWER PLANT ECONOMICS AND VARIABLE LOAD PROBLEM 123

To reduce the cost of building, it is desirable to eliminate the superstructure over the boiler house and as far as possible on turbine house also.

Adopting unit system where one boiler is used for one turbogenerator can reduce the cost on equipment. Also by simplifying the piping system and elimination of duplicate system such as steam headers and boiler feed headers. Eliminating duplicate or stand-by auxiliaries can further reduce the cost.

When the power plant is not situated in the proximity to the load served, the cost of a primary distribution system will be a part of the initial investment.

### **RATE OF INTEREST**

All enterprises need investment of money and this money may be obtained as loan, through bonds and shares or from owners of personal funds. Interest is the difference between money borrowed and money returned. It may be charged at a simple rate expressed as % per annum or may be compounded, in which case the interest is reinvested and adds to the principal, thereby earning more interest in subsequent years. Even if the owner invests his own capital the charge of interest is necessary to cover the income that he would have derived from it through an alternative investment or fixed deposit with a bank. Amortization in the periodic repayment of the principal as a uniform annual expense.

### **DEPRECIATION**

Depreciation accounts for the deterioration of the equipment and decrease in its value due to corrosion, weathering and wear and tear with use. It also covers the decrease in value of equipment due to obsolescence. With rapid improvements in design and construction of plants, obsolescence factor is of enormous importance. Availability of better models with lesser overall cost of generation makes it imperative to replace the old equipment earlier than its useful life is spent. The actual life span of the plant has, therefore, to be taken as shorter than what would be normally expected out of it.

The following methods are used to calculate the depreciation cost:

- (1) Straight line method
- (2) Percentage method
- (3) Sinking fund method
- (4) Unit method.

**Straight Line Method.** It is the simplest and commonly used method. The life of the equipment or the enterprise is first assessed as also the residual or salvage value of the same after the estimated life span. This salvage value is deducted from the initial capital cost and the balance is divided by the life as assessed in years. Thus, the annual value of decrease in cost of equipment is found and is set aside as depreciation annually from the income. Thus, the rate of depreciation is uniform throughout the life of the equipment. By the time the equipment has lived out its useful life, an amount equivalent to its net cost is accumulated which can be utilized for replacement of the plant.

**Percentage Method.** In this method the deterioration in value of equipment from year to year is taken into account and the amount of depreciation calculated upon actual residual value for each year. It thus, reduces for successive years.

**Sinking Fund Method.** This method is based on the conception that the annual uniform deduction from income for depreciation will accumulate to the capital value of the plant at the end of life of the plant or equipment. In this method, the amount set aside per year consists of annual installments and the interest earned on all the installments.

Let,

A = Amount set aside at the end of each year for  $n$  years.

$n$  = Life of plant in years.

S = Salvage value at the end of plant life.

$i$  = Annual rate of compound interest on the invested capital.

P = Initial investment to install the plant.

Then, amount set aside at the end of first year = A

Amount at the end of second year

= A + interest on A = A + Ai = A(1 + i)

Amount at the end of third year



$$\begin{aligned}
&= A(1+i) + \text{interest on } A(1+i) \\
&= A(1+i) + A(1+i)i \\
&= A(1+i)^2 \\
&\text{Amount at the end of } n\text{th year} = A(1+i)^n - 1 \\
&\text{Total amount accumulated in } n \text{ years (say } x) \\
&= \text{sum of the amounts accumulated in } n \text{ years} \\
&\text{i.e., } x = A + A(1+i) + A(1+i)^2 + \dots + A(1+i)^{n-1} \\
&= A[1 + (1+i) + (1+i)^2 + \dots + (1+i)^{n-1}] \dots(1) \\
&\text{Multiplying the above equation by } (1+i), \text{ we get} \\
&x(1+i) = A [(1+i) + (1+i)^2 + (1+i)^3 + \dots + (1+i)^n] \dots(2) \\
&\text{Subtracting equation (1) from (2), we get} \\
&x.i = [(1+i)^n - 1] A \\
&x = \frac{[(1+i)^n - 1]}{i} A, \text{ where } x = (P - S) \\
&P - S = \frac{[(1+i)^n - 1]}{i} A \\
&A = (P - S) \frac{i}{[(1+i)^n - 1]} A
\end{aligned}$$

**Unit Method.** In this method some factor is taken as a standard one and, depreciation is measured by that standard. In place of years equipment will last, the number of hours that equipment will last is calculated. This total number of hours is then divided by the capital value of the equipment. This constant is then multiplied by the number of actual working hours each year to get the value of depreciation

for that year. In place of number of hours, the number of units of production is taken as the measuring standard.

### OPERATIONAL COSTS

The elements that make up the operating expenditure of a power plant include the following

- (1) Cost of fuels.
- (2) Labour cost.
- (3) Cost of maintenance and repairs.

POWER PLANT ECONOMICS AND VARIABLE LOAD PROBLEM 125

- (4) Cost of stores (other than fuel).
- (5) Supervision.
- (6) Taxes.

### COST OF FUELS

In a thermal station fuel is the heaviest item of operating cost. The selection of the fuel and the maximum economy in its use are, therefore, very important considerations in thermal plant design. It is desirable to achieve the highest thermal efficiency for the plant so that fuel charges are reduced. The cost of fuel includes not only its price at the site of purchase but its transportation and handling costs also. In the hydro plants the absence of fuel factor in cost is responsible for lowering the operating cost. Plant heat rate can be improved by the use of better quality of fuel or by employing better thermodynamic conditions in the plant design.

The cost of fuel varies with the following:

- (1) Unit price of the fuel.
- (2) Amount of energy produced.
- (3) Efficiency of the plant.

### LABOUR COST

For plant operation labour cost is another item of operating cost. Maximum labour is needed in a thermal power plant using Coal as a fuel. A hydraulic power plant or a diesel power plant of equal capacity requires a lesser number of persons. In case of automatic power station the cost of labour is reduced to a great extent. However labour cost cannot be completely eliminated even with fully automatic station, as they will still require some manpower for periodic inspection etc.

### COST OF MAINTENANCE AND REPAIRS

In order to avoid plant breakdowns maintenance is necessary. Maintenance includes periodic cleaning, greasing, adjustments and overhauling of equipment. The material used for maintenance is also charged under this head. Sometimes an arbitrary percentage is assumed as maintenance cost. A good plan of maintenance would keep the sets in dependable condition and avoid the necessity of too many stand-by plants.

Repairs are necessitated when the plant breaks down or stops due to faults developing in the

mechanism. The repairs may be minor, major or periodic overhauls and are charged to the depreciation fund of the equipment. This item of cost is higher for thermal plants than for hydro-plants due to complex nature of principal equipment and auxiliaries in the former.

#### **COST OF STORES**

The items of consumable stores other than fuel include such articles as lubricating oil and greases, cotton waste, small tools, chemicals, paints and such other things. The incidence of this cost is also higher in thermal stations than in hydro-electric power stations.

126 POWER PLANT ENGINEERING

#### **SUPERVISION**

In this head the salary of supervising staff is included. A good supervision is reflected in lesser breakdowns and extended plant life. The supervising staff includes the station superintendent, chief engineer, chemist, engineers, supervisors, stores incharges, purchase officer and other establishment. Again, thermal stations, particularly coal fed, have a greater incidence of this cost than the hydro-electric power stations.

#### **TAXES**

The taxes under operating head includes the following:

- (i) Income tax
- (ii) Sales tax
- (ii) Social security and employee's security etc.

## ***POLLUTION & ITS CONTROL***

The atmosphere consists of a mixture of gases that completely surround the earth. It extends to an altitude of 800 to 1000 kms above the earth's surface, but is deeper at the equator and shallow at the poles. About 99.9% of the mass occurs below 50 km and 0.0997% between 50 and 100 km altitude. Major polluting gases/particles are confined to the lowermost layer of atmosphere known as Troposphere.

That extends between 8 and 16 kms above the earth surface.

The main sources of atmospheric pollution may be summarized as follows:

- (a) The combustion of fuels to produce energy for heating and power generation both in the domestic sector as well as in the industrial sector.
- (b) The exhaust emissions from the transport vehicles that use petrol, or diesel oil etc.
- (c) Waste gases, dust and heat from many industrial sites including chemical manufacturers, electrical power generating stations etc.

#### **ENVIRONMENT POLLUTION DUE TO ENERGY USE**

A considerable amount of air pollution results from burning of fossil fuels. Fuels are primarily derived from fossilized plant material and consist mainly of carbon and/or its compounds. The household sector is the largest consumer of energy in India, accounting for 40-50% of the total energy consumption. As per a report of Planning Commission the share of the household sector in the final use of energy declined although retaining its dominant share at 58.9% in 1987. The most abundantly used fossil fuel for cooking is the wood, which is almost 61% of the total fuel demand for cooking. Burning of traditional fuels introduces large quantities of CO<sub>2</sub> when the combustion is complete, but if there is incomplete combustion and oxidation then Carbon monoxide (CO) is produced, in addition to hydrocarbons.

Incomplete combustion of coal produces smoke consisting of particles of soot or carbon, tarry droplets of unburnt hydrocarbons and CO. Fossil fuels also contain 0.5-4.0% of sulphur which is oxidized to SO<sub>2</sub> during combustion.

The environmental effects of various fuels namely coal; oil, nuclear, etc. are of growing concern owing to increasing consumption levels. The combustion of these fuels in industries and vehicles has been a major source of pollution. Coal production through opencast mining; its supply to and consumption in power stations; and industrial boilers leads to particulate and gaseous pollution, which can cause pneumoconiosis, bronchitis, and respiratory diseases. Another major impact of coal mining is land

degradation, especially of forest areas.

The consumption of petroleum products in vehicles, industries and domestic cooking activities results in the emission of pollutants in large quantities. Radioactive emissions from nuclear power plants are of grave concern as they can cause serious impact both in terms of spatial and inter-generational concerns. In addition, two key problems are long-term waste disposal and the eventual decommissioning of plants. Due to limited reserves of petroleum, main emphasis needs to be given to non-conventional energy sources such as wind energy, solar energy and ocean energy.

### **ENVIRONMENT POLLUTION DUE TO INDUSTRIAL EMISSIONS**

Air borne emissions emitted from various industries are a cause of major concern. These emissions are of two forms, viz. solid particles (SPM) and gaseous emissions (SO<sub>2</sub>, NO<sub>x</sub>, CO, etc.). Liquid effluents, generated from certain industries, containing organic and toxic pollutants are also a cause of concern. Heavily polluting industries were identified which are included under the 17 categories of highly polluting industries for the purpose of monitoring and regulating pollution from them. The Ministry of Environment and Forests has, over the last two decades, developed standards for regulating emissions from various industries and emission standards for all the polluting industries including thermal power stations, iron and steel plants, cement plants, fertilizer plants, oil refineries, pulp and paper, petrochemicals, sugar, distilleries and tanneries have been prescribed. The industrial units in India are largely located in the States of Gujarat, Maharashtra, Uttar Pradesh, Bihar, West Bengal and Madhya Pradesh. The highest concentration of sulphur dioxide and oxides of nitrogen is therefore often found in cities located in these states. Some other industrial estates in Delhi, Punjab, Rajasthan and Andhra Pradesh are also becoming critical.

### **ENVIRONMENT POLLUTION DUE TO ROAD TRANSPORT**

Road vehicles are the second major source of pollution. They emit CO, HCs, NO<sub>x</sub>, SO<sub>2</sub>, and other toxic substances such as TSP and lead. Diesel engines are much less polluting than petrol engines. Both types of engines are not very efficient converters of fuel energy. However, diesel types, with a conversion efficiency of around 30%, must be more efficient and use less fuel than petrol types with 15-20% conversion efficiency. Both types of engines have incomplete combustion of fuel so the major pollutant is CO, amounting to 91% by weight of all vehicle emissions.

The primary pollutants produced in vehicle emissions undergo a series of complex interrelated chemical reactions in the troposphere and lower stratosphere to form secondary products.

Four factors make pollution from the vehicles more serious in developing countries.

- (1) Poor quality of vehicles creating more particulates and burning fuels inefficiently.
- (2) Lower quality of fuel being used leads to far greater quantities of pollutants.
- (3) Concentration of motor vehicles in a few large cities
- (4) Exposure of a larger percentage of population, that lives and moves in the open.

### **HARMFUL EFFECTS OF EMISSIONS**

The high concentration of particulates in the atmosphere over large urban and industrial areas can produce a number of general effects. Smoke and fumes can increase the atmospheric turbidity and reduce the amount of solar radiation reaching the ground. The overall effect of air pollution upon the biosphere and the built environment can be broadly considered under 3 headings: The effect upon:

416 POWER PLANT ENGINEERING

- (1) Buildings and materials
- (2) Soil, vegetation, crops and animal life
- (3) Human beings

### **BUILDING AND MATERIALS**

The fabric of buildings, that are surrounded by heavily polluted air for years undergo chemical changes. Gradual erosion takes place and this is only too evident when grimy upper surface is removed. A good example is that of the famous historical monument 'Taj Mahal' at Agra, which, on account of reaction of Sulphur-di-oxide, emitted from neighbouring industries, with the limestone has slowly, started turning yellow. As a result, on Court's directives, a number of measures have been taken to protect our national heritage monument *e.g.* closure of neighbouring heavy polluting industries, operation of only non-polluting vehicles like battery busses, tonga in the vicinity of Taj Mahal etc.

## **SOIL, VEGETABLE AND ANIMAL LIFE**

The presence of gaseous pollutants in the air and deposition of particulates on to the soil can affect plants. It can affect the cattle and animals too as they have been found to develop breathing difficulties and suffer from low yield of milk, lameness and joint stiffness in a polluted environment.

## **HUMAN BEINGS**

Smoke and SO<sub>2</sub> cause the general and most widespread effects of air pollution on people. Atmospheric smoke contains potentially carcinogenic organic compounds similar to those that occur in cigarette tobacco smoke. The CO affects the cardiovascular system, NO<sub>x</sub>s affect the respiratory system, Ozone causes increased sensitivity to infections, lung diseases, irritation in eyes, nose and throat etc.

## **STEPS TAKEN SO FAR AND THEIR IMPACT**

With the alarming increase in the s, especially in the big cities, Government has taken some important initiatives in the recent years. To start with the emphasis and implementation has been primarily in the big cities but gradually to spread throughout the country. These relate to the progressive tightening of the auto-emission norms (1991,1996,1998 & 2000) and fuel quality specifications (1996) as recommended by the Central Pollution Control Board (CPCB).

Till early 1994 ambient air quality standards in India were based on 8 hourly average times only.

In April 1994, these standards were revised and 24 hourly standards were also prescribed. National ambient air quality standards are prescribed for three distinct areas viz.

- (a) Industrial,
- (b) Residential, rural and other areas and
- (c) Sensitive areas.

Following steps have been taken so far:

**(1) Unleaded Petrol.** With the gradual reduction of lead content in petrol and finally supply of unleaded petrol for all vehicles from Sept. 1998 in the capital city of Delhi, a lethal pollutant from vehicular exhaust has been removed. The lead content in the atmosphere near traffic intersections of Delhi has reduced by more than 60% with this measure.

POLLUTION AND ITS CONTROL 417

**(2) Sulphur in diesel.** The sulphur content in the diesel supplied has been reduced from 0.5% in 1996 to 0.25% in 1997 so as to meet the EURO-II norms.

**(3) Tightening of the Vehicular Emission Norms.** From 1995 new passenger cars were allowed to register only if they were fitted with catalytic converters. Emission norms for such cars were tightened by 50% as compared to 1996 norms. With the recent directions of the Hon'ble Supreme Court, passenger cars (both petrol and diesel) are required to meet atleast EURO-I norms in June 1999 and from Apr. 2000 only such vehicles meeting EURO-III norms will be permitted to register in the NCR of Delhi. CNG operated vehicles are also permitted by the Supreme Court directions.

**(4) 2-T Oil for Two Stroke Engines.** From 1.04.99, on the recommendations of CPCB, the low smoke 2T oil became effective. To prevent the use of 2T oil in excess of the required quantity premixed 2T oil dispensers have been installed in all the petrol filling stations. Sale of loose 2T oil has also been banned from Dec. 1998.

**(5) Phasing out of Grossly Polluting Vehicles.** On CPCB's recommendations initially 20 yr. old vehicles were prohibited from plying from Dec.1998, followed by phasing out of 17 yr. old vehicles from Nov. 1998 and 15 yr. old from Dec. 1998.

## **NOISE POLLUTION AND ITS CONTROL**

Of late, noise has been recognized as a pollutant which until recently was considered only as a nuisance. The Central Pollution Control Board (CPCB) has notified the ambient noise standards in 1987 under section 20 of the Air (Prevention and Control of Pollution) Act, 1981. The noise standards specify limits as 55dBA and 45dBA as limits for day and night time respectively for residential areas, 75 dBA and 70dBA in the day and night time for industrial areas, and 50 dBA and 40 dBA in the day and night for silence zones. Special campaign for reduction in use of fire crackers in Delhi have resulted in reduced pollution levels during Diwali in 1999.

The creation of noise creates the pollution by increasing the sound level of the atmosphere. It is estimated that the environmental sound level is doubling in loudness after every 10 years. The increase in sound level of the atmosphere is not the major problem presently but desirable sound level is essential

in power plants and every step should be taken to reduce the sound level of the power plants to a tolerable level.

Heavy noise environment has extremely unpleasant effects on people exposed to them. Continuous exposure to noise level above 100 dBA has adverse effect on hearing ability within a short time.

Therefore, in world energy conference of 1971, a study of noise suppression in thermal power plants occupied a major percentage of the, seminars conducted.

Presently enough attention has been given in many developed countries to reduce the noise level in the power plants to the tolerable level.

The curves derived from hearing tests made on workers show that within 10 years, over 10% of employees subject to 8 hours a day of 95 dBA noise level will suffer from hearing impairment and that of 40 years, 20°/v will be affected to the same extent by the noise level of 92 dBA.

## **GREEN HOUSE GASES AND THEIR EFFECTS**

The greenhouse effect plays a crucial role in regulating the heat balance of the earth. It allows the incoming short-wave solar radiation to pass through the atmosphere relatively unimpeded; but the longwave

terrestrial radiation emitted by the earth's surface is partially absorbed and then re-emitted by a number of trace gases in the atmosphere. These gases known as GHGs (greenhouse gases) are: water vapor, carbon dioxide, methane, nitrous oxide and ozone in the troposphere and in the stratosphere. This natural greenhouse effect warms the lower atmosphere.

If the atmosphere were transparent to the outgoing long wave radiation emanating from the earth's surface, the equilibrium mean temperature of the earth's surface would be considerably lower and probably below the freezing point of water. Mere incidence of GHG's in the atmosphere, by itself, is no concern. What is more important is that their concentration should stay within reasonable limits so that global ecosystem is not unduly affected. However, by increasing the concentrations of natural GHG's and by adding new GHG's like chloroflouro carbons the global average and the annual mean surface-air temperature (referred to as the global temperature) can be raised, although the rate at which it will occur is uncertain. This is the enhanced greenhouse effect, which is over and above that occurring due to natural greenhouse concentration. Such a rise in the atmospheric concentration of GHG's has led to an upward trend in global temperature.

While it is required to follow the general commitments under the Framework Convention on Climate Change, India is not required to adopt any GHG reduction targets. Irrespective of international commitments, it seems prudent to ready with

1. Inventory of sinks and sources of GHG emission.
2. Predict the cumulative impact of national and international GHG emissions to plan for temperature and sea level rise.
3. Devise landuse plans for the coastal areas likely to be affected.
4. Devise water and land management strategies especially agricultural sector.

## **FOSSIL FUEL POLLUTION**

The exhaust gases and particulate matter emitted from combustion systems affect the environment in several ways. The major classifications are:

### **URBAN AIR POLLUTION**

It includes:

#### **1. Photochemical smog**

The reactants are nitric oxide (NO), unburned hydrocarbons (UHCs), and sunlight (*i.e.*, photons).

The products (after a few hours of time) are oxidants such as ozone (O<sub>3</sub>) and peroxyacetyl nitrate (PAN = CH<sub>3</sub>CO<sub>3</sub>NO<sub>2</sub>), aldehydes (RCHO, where R = a hydrocarbon radical, *e.g.*, the methyl radical, CH<sub>3</sub>), and aerosol haze.

An intermediate product is nitrogen dioxide (NO<sub>2</sub>), which gives a brownish color to the atmosphere and reaches a peak concentration about half way through the reaction process, at the time at which the original NO is significantly converted to NO<sub>2</sub>. The smog products are eye irritants and they diminish



lung capability. The different hydrocarbon gases have significantly different smog forming potential. Methane, for example, is very unreactive, whereas ethylene (C<sub>2</sub>H<sub>4</sub>) and propylene (C<sub>3</sub>H<sub>6</sub>) are quite reactive. Thus, the smog impact of the hydrocarbon emitted is determined not only by its concentration, but also by its photochemical reactivity.

## 2. Carbon monoxide (CO)

## 3. Sulfur dioxide (SO<sub>2</sub>)

## 4. Nitrogen dioxide (NO<sub>2</sub>)

## 5. Toxic gases, vapors, and heavy metals

## 6. Particulate matter

### ACID RAIN

The precursors of which are nitric oxide (NO) and sulfur dioxide (SO<sub>2</sub>). Over hours and days the NO and SO<sub>2</sub> oxidize to NO<sub>2</sub> and SO<sub>3</sub>, respectively, which subsequently form acids of nitrogen and sulfur. Because of the relatively long time for the chemical transformations to occur, the impact of the acid is generally felt several hundred kilometers downwind of the sources. The sulfur also forms sulfate aerosol. Sulfate aerosol reflects sunlight and is thought to be keeping some industrialized parts of the world cooler than they would otherwise be. That is, these industrialized parts of the world are not receiving proper warming by the greenhouse effect.

### GLOBAL CLIMATE CHANGE

It also knows as the Greenhouse Effect. The major greenhouse gases are CO<sub>2</sub>, CH<sub>4</sub>, nitrous oxide (N<sub>2</sub>O), and chloro-fluoro-carbon species (*i.e.*, CFCs), though ozone and soot also play a role. The Greenhouse Effect is already discussed.

### STRATOSPHERIC OZONE DEPLETION

Due to gases such as CFC's and NO. Fossil fuel combustion is a very significant cause of Urban Air Pollution and Acid Rain, and is strongly implicated in Global Climate Change. However, landbased combustion systems, with the exception of Fluidized Bed Coal Combustors, are not strongly implicated in Stratospheric Ozone Depletion. This is because pollutants from land-based sources capable of destroying ozone (such as NO) do not reach the stratosphere — they are destroyed in the troposphere. Fluidized Bed Coal Combustion, on the other hand, though attractive because of its low emissions of SO<sub>2</sub> and NO, has a high exhaust emission of N<sub>2</sub>O (of several hundred parts per million). Although N<sub>2</sub>O is not toxic — it is laughing gas — it is a greenhouse gas and it has few enemies in the troposphere. Thus, it reaches the stratosphere where it breaks down into NO, which is an ozone depleting gas. Conversion of the N<sub>2</sub>O to NO can occur as follows in the stratosphere:



The NO depletes the ozone, without depleting itself, as follows:



Overall, an O<sub>3</sub> is lost, and an O-atom, which could have formed O<sub>3</sub> through the reaction below, is lost.



### ACID FOG

A recently noted major acid pollutant is acid fog. Its origin is the same as acid rain or snow, *i.e.*, sulfuric and nitric oxides from power plants and, to a lesser extent, motor vehicles. It forms by the mixing of these pollutants with water vapor near the ground. The acid vapors then begin to condense around very tiny particles of fog or smog, pick up more water vapor from the humid air, and turn into acid fog. When the water in the fog burns off (evaporates) due to the sun or other causes, drops of nearly pure sulfuric acid are left behind. It is these drops that make acid fog so acidic. In Los Angeles and Bakersfield in southern California, the mists have a pH of 3.0 compared with 4 or 4.5 for acid rain. Acid fog 100 times as acidic as acid rain has been detected. Cases have been reported where people had

POLLUTION AND ITS CONTROL 421

trouble breathing when it was foggy. The problems of fog are now believed by some to be more serious than those of smog in these areas.

Many researchers consider the effects of acid precipitation, especially the changing of soil chemistry,



to be irreversible and fear its long-range effects. Monitoring programs of air, soil, and water are being instituted to ascertain these long-range effects. However, the uncertainty about the real extent of the problem adds to the prevailing disquiet regarding it.

## POLLUTION DUE TO COMBUSTION OF FUEL

### Gas Fuel

When a gaseous fuel, such as natural gas, burns it undergoes a series of processes. These are as follows:

Either in a premixer or in the combustion chamber, the fuel must mix with air.

The fuel (and the air) must mix with hot, burning and burnt gases present in the chamber. The burning and burnt gases provide heat and active species (O, H, and OH), which upon mixing with the fresh fuel and air cause the fresh fuel to ignite and react with the air.

The fuel then undergoes a series of chemical reactions.

### METHANE

If the fuel is methane (the primary constituent of natural gas), the following reaction steps occur. Due to the heat and attack by the active species, the methane reacts to a methyl radical (CH<sub>3</sub>), which reacts to formaldehyde (HCHO). The formaldehyde reacts to a formal radical (HCO), which then forms carbon monoxide (CO). Through these steps, the active species are used up and H<sub>2</sub> and H<sub>2</sub>O are formed in addition to the CO. Overall, the process is as follows:



Thus, the original fuel is converted into two new fuels (CO and H<sub>2</sub>) and into one product (H<sub>2</sub>O). The process occurs very quickly, within a fraction of a millisecond to a few milliseconds, depending

on the flame temperature, pressure, and fuel-air ratio. (Actually, methane is one of the slower burning hydrocarbon gases.) The process is called **Oxidative Pyrolysis**.

Following oxidative pyrolysis, the H<sub>2</sub> oxidizes, forming H<sub>2</sub>O, replenishing the active species, and releasing heat. This occurs very quickly, usually in less than a millisecond.

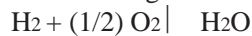

Finally, the CO oxidizes, forming CO<sub>2</sub> and releasing more heat. This process is generally slower than the other chemical steps, and typically requires a few to several milliseconds to occur.

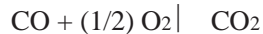

The combustor may be thought of as having **flame zones**, in which the free radical activity is high, the fuel undergoes oxidative pyrolysis, the hydrogen oxidizes, and the CO begins to oxidize, and a **post-flame zone**, in which the CO continues to oxidize and reaches its final exhaust concentration.

422 POWER PLANT ENGINEERING

### ALKANES

When Alkanes (C<sub>n</sub>H<sub>2n+2</sub>) of n = 2 and above are burned, the reaction chemistry is different from that of the methane. First, the Alkanes undergo conversion to one or more alkenes (C<sub>n</sub>H<sub>2n</sub>), especially to ethylene (C<sub>2</sub>H<sub>4</sub>) and propylene (C<sub>3</sub>H<sub>6</sub>). The alkenes then undergo oxidative pyrolysis reaction to CO, H<sub>2</sub>, and H<sub>2</sub>O, but through a different chemical mechanism than given above for methane. The overall reactions are:

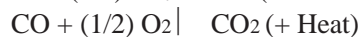
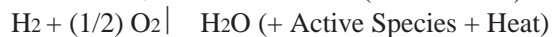

## POLLUTION DUE TO GAS COMBUSTION

### UNBURNED HYDROCARBONS (UHCs)

Any fuel entering a flame will be reacted. Thus, when unburned fuel is emitted from a combustor, the emission is caused by fuel 'avoiding' the flame zones. For example, in piston engines, fuel-air mixture 'hides' from the flame in the crevices provided by the piston ring grooves. Further, some regions of the combustion chamber may have a very weak flame, that is, they have either very fuel-lean or very fuel-rich conditions and consequently they have a low combustion temperature. These regions will cause intermediate species such as formaldehyde and alkenes to be emitted. Sometimes the term 'products

of incomplete combustion,' or PICs is used to describe such species. The term UHC represents the sum of all hydrocarbon species emitted.

### CARBON MONOXIDE (CO)

Carbon monoxide is emitted because the temperature is too low to effect complete oxidation of the CO to CO<sub>2</sub>, because the time (*i.e.*, the residence time) available in the combustion chamber is too short, or because there is insufficient oxygen present. Usually, it is more difficult to design and operate a combustor for very low CO than for very low unburned hydrocarbons. Exhaust emissions of CO are controlled by providing the combustor with sufficient air to assure oxidation of the CO. However, too much air is 'bad,' since then the post-flame zone will be too cool to oxidize the CO. Catalysts in the exhaust stream are also used to control CO. These provide about a 90% conversion of the CO to CO<sub>2</sub>, and typically use platinum (or a mixture of platinum group metals) as the active sites (on a ceramic or metal substrate) to oxidize the CO. Almost all automobiles sold today in the US and in many other countries are equipped with three-way catalysts. By running the engine at stoichiometric fuel-air ratio, there is enough O<sub>2</sub> left in the exhaust to effect oxidation of the CO and UHCs in the catalyst, and there is a sufficient quantity of reducing species in the exhaust to effect chemical reduction of the NO<sub>x</sub> to N<sub>2</sub>. Thus, the three 'ways' are CO, UHCs, and NO<sub>x</sub>.

### NITRIC OXIDE (NO<sub>x</sub>)

Nitric oxide forms by attack of O-atoms on N<sub>2</sub>. The predominant mechanism is the extended Zeldovich mechanism:

POLLUTION AND ITS CONTROL 423



When this process occurs in the post flame zone, the resulting NO is called thermal NO, because the amount of NO formed is strongly temperature sensitive. In order to limit the amount of NO formed, it is necessary to reduce the combustion temperature (which is generally very effective because of the strong temperature dependency of the NO formation), reduce the residence time (though this will in general increase the CO emission), or limit the availability of oxygen.

NO also forms in the flame zone. In this case, the O-atom and OH concentrations affecting the formation of NO have much higher concentrations than in the post-flame zone. Other mechanisms also contribute, such as the prompt mechanism:



The hydrogen cyanide (HCN) and N-atom oxidize to NO. Because of the high free radical concentrations in the flame zone, the rate of production of NO is faster in the flame zone than in the post flame zone. However, the time available in the flame zone is generally short compared to the time available in the post-flame zone.

Some of the NO may oxidize to NO<sub>2</sub> in the combustor. Thus, the emission is expressed as NO<sub>x</sub> = NO + NO<sub>2</sub>.

Many methods are used to control the emission of NO<sub>x</sub>, and a great deal of research has been done on this. A great deal of money is spent on NO<sub>x</sub> control throughout the world. As indicated above, automotive NO<sub>x</sub> is controlled though the use of the three-way catalyst. Another name for this is nonselective

catalytic reduction (NSCR). Some industrial and utility combustors use a different type of exhaust catalyst. This is a selective catalytic reduction or SCR. In this case, ammonia (NH<sub>3</sub>) is injected into the exhaust stream ahead of the catalyst. Across the catalyst, the NO<sub>x</sub> and NH<sub>3</sub> react to form N<sub>2</sub>. The conversion efficiency is about 80 to 90%.

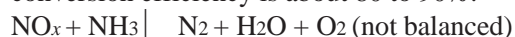

Another method with ammonia injection is selective non-catalytic reduction (SNCR). If ammonia is injected into the exhaust at higher temperatures (*i.e.*, at about 1200K) than used in the SCR process, the ammonia reduces the NO<sub>x</sub> without the need for the catalyst. However, if the temperature is too high, the ammonia oxidizes into NO.

Combustion modification is also widely practiced to control NO<sub>x</sub> and a whole class of low-NO<sub>x</sub> engines and combustors has grown up. These have NO<sub>x</sub> emissions anywhere from about 10% to 70% of the 'dirty' pre-NO<sub>x</sub>-control combustors. The concepts used to effect the NO<sub>x</sub> control are no mystery. Reduction of combustion temperature is very effective, thus, injection of water, or a diluents such as

steam or recycled exhaust (or flue) gas, is widely practiced. Another diluent is air, and thus, lean premixed combustion is very effective in controlling  $\text{NO}_x$ . Another method widely used is staged combustion. That is, the first stage of combustion is conducted fuel rich. This creates a lot of CO and UHCs, but it doesn't create much  $\text{NO}_x$  because of the lack of  $\text{O}_2$ . Some heat is transferred from the rich gases (for example, to the working fluid of a steam-electric power-plant burner), and then the remaining air is added into the flame to burn off the CO and UHCs. Now,  $\text{NO}_x$  formation is limited, because of the reduced combustion temperature.

## **SOOT**

Soot is composed of particles of a few hundred angstroms in size. Generally, soot is a fluffy carbon material, though it is generally not pure carbon. Soot forms under hot, fuel-rich conditions, and, once formed, oxidizes relatively slowly. (Soot requires on order of 100 milliseconds to oxidize at typical combustion temperatures.) Soot is controlled by adding air to the flame zone, thus eliminating the hot, rich pockets of gas, which produce it, or by providing a secondary combustion zone of sufficient  $\text{O}_2$ , temperature, and time to oxidize the soot.

A low emission combustor would have CO and  $\text{NO}_x$  exhaust concentrations of less than about 100 ppm (parts per million by volume) each, and an UHC emission of under about 10 ppm. A very low emission system would have CO and  $\text{NO}_x$  of about 10 ppm each, and UHC less than a few ppm's. High emission burners have CO and  $\text{NO}_x$  emissions in the several hundred to a few thousand-ppm ranges. New combustors and emission control methods are being developed 'every day,' and for some situations the goal of 'zero emissions' is being approached. Of course, the term 'zero emissions' does not mean absolute zero emission. It depends somewhat on the 'reference point.' Generally, it means CO and  $\text{NO}_x$  emissions in the few ppm range. For example, Honda recently announced a special new exhaust catalyst system, which gives very low emissions.

## **POLLUTION DUE TO LIQUID FUEL**

When a liquid fuel, such as oil, is burned, there are additional aspects of the combustion process and the pollutant formation. Specifically:

### **ATOMIZATION**

It is common practice to inject the fuel into the combustor (or pre-mixer) through a nozzle, which atomizes the fuel. That is, the continuous stream of fuel is broken up into a mist of tiny droplets. There are many types of nozzles, some of which rely on very high feed pressures to atomize the fuel, and some of which rely on assistance from steam and air to effect good atomization. Generally, the finer the spray produced by the nozzle the better the combustion process.

### **VAPORIZATION**

The fuel droplets vaporize as they receive heat by mixing with the hot gases in the combustion chamber. Heat can also be received by radiation from any hot refractory wall of the combustion chamber.

## **MODES OF COMBUSTION**

If the vaporization process is fast compared to the reaction chemistry, the combustion of the liquid fuel occurs mainly as clouds of vapor. Thus, the sequence of processes is atomization, vaporization, mixing, and chemical reaction, and the 4-step chemical mechanism given above under Alkanes is valid. On the other hand, if the vaporization process is slow, droplet burning can occur. That is, individual flames may encircle individual droplets, thereby effecting oxidation of the oil. Generally, though not necessarily, the UHC, CO, and  $\text{NO}_x$  emissions increase with oil burning compared to gaseous fuel burning. There are several reasons for this, including:

- The additional time required for vaporization,
- The more complex hydrocarbons involved in the fuel,
- Poorer mixing of the fuel vapor with the air,
- Higher localized temperatures (leading to higher  $\text{NO}_x$ ),
- And the formation of deposits in the combustor which can adversely affect combustion 'goodness' by affecting flame shape and burner aerodynamics.

Also, some liquid fuels contain sulfur, organic nitrogen, and mineral elements, which lead to

additional pollution. Generally, distillate fuel oil and diesel fuel are low in these compounds, and gasoline and aviation fuel are even lower yet in these compounds. Other (heavier) fuel oils are relatively high in these compounds. Sulfur in the fuel reacts essentially completely to sulfur dioxide (SO<sub>2</sub>) upon combustion.

Also, a small fraction of the sulfur oxidizes to sulfur trioxide (SO<sub>3</sub>), which is a problem because it will readily form sulfur acid mists if the exhaust temperature is too low. Thus, in order to prevent corrosion of the energy system equipment, the exhaust temperature may be maintained higher than it would be without the sulfur. Thus, thermodynamic efficiency is degraded, and the ratio of CO<sub>2</sub> to unit of electrical energy produced increases. Sulfate particulate emission can also result from the sulfur. (Within the 3-way catalyst of an automotive engine, the small amount of SO<sub>2</sub> present can be reduced to hydrogen sulfide (H<sub>2</sub>S). Ever smell this?) Organic nitrogen in the fuel, also called fuel-bound nitrogen, will end up partly as NO<sub>x</sub> upon combustion and partly as N<sub>2</sub>. Staged combustion generally promotes the N<sub>2</sub> end point over the NO<sub>x</sub> end point. Mineral matter in the oil can cause several problems, including deposits and flyash emissions. The deposits can promote reactions, which affect the other pollutants, such as SO<sub>2</sub>.

About 65% of the oil used in the US is used by the transportation sector that about 25% is used by industry, and that most of the balance is used for residential and commercial heating. Very little is used in the US for electrical generation. Most of the discussion in the paragraph immediately above pertains to industrial, utility, and R/C burning of oil. However, the biggest sector involved in the control of emissions from oil burning is the transportation sector, because the fuels burned by this sector (*i.e.*, gasoline and diesel fuel) are mainly derived from oil. Thus, advancements in engine combustion technology

and catalytic exhaust treatment are very important to the control of emissions from oil burning. A major challenge is the development of automotive exhaust treatments which work well for fuel-lean engine combustion. This is important because engines are thermodynamically more efficient when operated

with excess air. However, the present 3-way catalyst has a poor NO<sub>x</sub> reduction efficiency when the engine is operated lean. Another major challenge is control of NO<sub>x</sub> and soot particulate from diesel engines. The oil problem is being addressed with advanced combustion technology and exhaust particle traps.

## **POLLUTION DUE TO SOLID FUEL**

The solid fuel of primary interest is coal. In power plant generally coal is burned for electrical generation.

Coal is burned in several ways, depending on coal particle size. Lumps of coal, including coal particles larger than about 0.25 inch in diameter, are spread on a grate and burned. Conceptually, this is not unlike the burning of wood logs in a fireplace, though industrial and utility coal grate burners are substantially more sophisticated than a fireplace. There is a limit to the size of a grate, (around the order 10 meters square is maximum). Grate coal burners are called Stokers. Stokers come in several forms, and are used for small and medium size coal combustion systems.

426 POWER PLANT ENGINEERING

Coal particles of about 1/8th inch diameter are burned in fluidized bed coal combustors (FBC). In this system, the coal particles are injected into a bed of limestone or dolomite particles strongly churned or agitated by blowing air through the bed from below. The bed has the appearance of "boiling." The fluidizing medium is limestone (or dolomite), rather than ordinary sand (which could be used), so that the sulfur from the coal is taken up by the limestone and converted into calcium sulfate particles (CaSO<sub>4</sub>), which are periodically or continuously removed from the bed. Also, thermal NO formation is very low because of the relatively low combustion temperature of the bed (about 800 to 900°C). In addition, flyash emission is controlled to some extent by retaining the ash in the bed. However, the nitrogen contained in the coal, *i.e.*, the fuel-bound organic nitrogen, converts to nitrous oxide (N<sub>2</sub>O). If the bed temperature were higher than 800-900°C, the fuel-bound nitrogen would convert to NO<sub>x</sub>. Fluidized bed coal combustion is a relatively new commercial technology, which appears to be favored more in Europe than the US.

Although the Stoker and Fluidized Bed technologies are important, the majority of the coal burned in steam-electric power plants is burned in Pulverized Coal Combustion Furnaces. Pulverized coal is coal, which has been ground (*i.e.*, pulverized) into a fine dust, of about 70 micrometers (*i.e.*, microns) mean diameter. Pulverized coal combustors are suspension burners - that is, the coal dust is carried by the furnace air and gases and burned in suspension.

In all solid fuel burners, the fuel undergoes heating and devolatilization as the first stage of the burning process. Devolatilization is analogous to the vaporization process for the liquid fuel. Devolatilization means that part of the solid fuel decomposes and forms gases and tars upon heating. The fraction of the fuel, which forms volatiles, and the composition of the volatiles depend on the nature of the fuel and the particle heating process. Typically, a combustion coal is about 50% volatile matter by weight. The volatiles released from the coal are made up of the following components: CO, H<sub>2</sub>, light hydrocarbon gases (such as methane, ethane, ethylene, and propane), oxygenated hydrocarbons, medium molecular weight hydrocarbons, high molecular weight hydrocarbons called tars (which are vapor at furnace temperatures), and inert gases (such as CO<sub>2</sub> and H<sub>2</sub>O). The volatiles burn via a mechanism similar to that described above for the Alkanes. Typically, devolatilization occurs within 100 milliseconds, and the volatiles burning occur within a few milliseconds. The particles remaining after devolatilization are composed of char (*i.e.*, mainly carbon) and ash (*i.e.*, mineral matter). Following the release of volatiles from the solid fuel particle, it is possible for oxygen to diffuse to the surface and oxidize the char particle. Char particle oxidation requires about 100 to several hundred milliseconds of time. The furnace volume has to be big enough to accommodate this. The following reactions happen at the char particle surface (including surfaces created by fissures in the particle):

As the char particle burns away, the mineral matter imbedded in the coal as small inclusions gets very hot, becomes molten, and fuses together to form liquid ash particles, which ultimately solidify. Typically, 3 to 5 'big' ash (*i.e.*, flyash) particles form per original pulverized coal particle. Additionally, the volatile mineral matter vaporizes during the devolatilization and char burning stages, and forms tiny, sub-micron particles upon nucleation and condensation. The sub-micron particles can be more of a problem than the 'big' (1 to 10 micron) particles, because the sub-micron particles tend to carry disproportionate amounts of the toxic heavy metals found in coal. A toxic heavy metal emitted as a gas is mercury.

It should be noted that coal contains about every element found in nature. Although C, H, and O are the major elements found in coal, there can also be significant amounts of S and N. Some coals have

POLLUTION AND ITS CONTROL 427

as much as 10% S by weight. The sulfur is contained in both the organic and inorganic fractions of the coal. It is possible to remove some of the sulfur containing 'rocks' found with the coal using gravity separation methods. Processes have been studied for removing additional amounts of S from coal; however,

these processes are not widely used commercially.

Coal contains about 0.5 to 1.5% by weight N bound into the organic structure of the coal. When the coal is heated, much of the N is released during the devolatilization stage as hydrogen cyanide (HCN), other cyano species, and as ammonia (NH<sub>3</sub>). These species are rapidly converted into NO or N<sub>2</sub>, and thus are not emitted directly from the combustor.

Some coals (*e.g.*, British coals) contain chlorine, which upon combustion can be emitted as hydrogen chloride (HCl).

Typically, coal has about 10% by weight mineral matter. This mineral matter is high in Si, Al, Fe, and Ca and these are the primary elements found in the 'big' flyash particles. However, many other inorganic elements are associated with the mineral matter of coal, including Mg, Na, and K. Toxic metals are found in trace amounts in coal, including Ni, Pb, Cd, Cr, As, Se, and Hg. Generally, the toxic metals are found associated with the sub-micron flyash, though Hg will be emitted as a gas. Radioactive isotopes are also emitted from coal combustors. It has been estimated that more radioactivity is emitted from a coal combustion power plant than from a nuclear power plant. Emission control is practiced as follows for Pulverized Coal Furnaces:

A significant fraction of the **installed** cost of a coal-fired electrical generating station is devoted to environmental control — about 30 to 40%. Also, a significant fraction of the **operating and maintenance**

cost is devoted to environmental control. Sulfur (*i.e.*, SO<sub>2</sub> emission) is controlled by burning a low sulfur coal, by pre-combustion coal cleaning, and by flue gas desulfurization.

NO<sub>x</sub> is controlled by the use of low-NO<sub>x</sub> burners, by SNCR, and by SCR. Note that NO<sub>x</sub> is formed from both the air nitrogen and the fuel-bound nitrogen.

Flyash is controlled by stack gas particulate removal using electrostatic precipitators (ESPs) or baghouses (*i.e.*, the stack gas is filtered).



Coal is also burned by gasifying it and burning the gases in a gas turbine engine, which is part of a combined cycle. There are about five integrated gasification combined cycle (IGCC) power plants operating in the US. The combustible compounds present in the gas (*i.e.*, the synthetic gas) are mainly H<sub>2</sub> and CO, though in some cases CH<sub>4</sub> is also present in significant amounts. Other gases present are CO<sub>2</sub>, H<sub>2</sub>O, and N<sub>2</sub>. If the gasifier is 'air blown' there is a lot of N<sub>2</sub> present (about 30 to 50% by volume), and thus the gas has a low heating value (of about 100 to 200 Btu/scf). If an oxygen-blow gasifier is used, the heating value is in the medium Btu range (about 1/4 to 1/2 that of natural gas), though the power-plant now must also include an air separation plant for making O<sub>2</sub> — actually, oxygen enriched air is produced. The gas is cleaned to remove sulfur (as H<sub>2</sub>S) and particulate matter before entering the gas turbine. Some gasifier product streams carry several thousand ppms of NH<sub>3</sub> (formed from the coalbound nitrogen), which needs be controlled either by scrubbing or by special combustion methods, so that it does not react to NO<sub>x</sub> in the combustor. However, other gasifiers emit only about 200 ppm ammonia, and when this gas is burned in a gas turbine, the sum of the fuel-NO<sub>x</sub> and thermal NO<sub>x</sub> leaving the burner is only about 30 to 40 ppm. For reference, when natural gas is used as the fuel in a gas turbine engine equipped with state-of-the-art, commercially available, lean premixed combustors, the NO<sub>x</sub> emission is about 9 to 25 ppm (depending on the make and model of the engine.) The coal IGCC system has an overall efficiency in the low 40% range, whereas the natural gas fired combined cycle is about 50 to 58% efficient (as discussed earlier). The IGCC system has higher CO<sub>2</sub> per kW-hr than the natural gas fired system.

## **AIR POLLUTION BY THERMAL POWER PLANTS**

The environmental pollution by thermal power plants using fossil fuels poses a serious health hazard to modern civilization. Air pollution by thermal plants is a contributing factor in the cause of various respiratory diseases and lung cancer and causes significant damage to the property in addition to causing annoyance to the public.

The thermal power plants burning conventional fuels (coal, oil or gas) contribute to air pollution in a large measure. The combustible elements of the fuels are converted to gaseous products, and noncombustible

elements as ash. The common gaseous products of interest are sulphur dioxide, nitrogen oxide, carbon dioxide and carbon monoxide, and large quantities of particulate materials as fly ash, carbon particles, silica, alumina and iron oxide.

The energy industries are one of the largest sources of environmental pollution. A 350 mW coalfired station emits about 75 tons of SO<sub>2</sub>, 16 tons of nitrogen oxide, and 500 tons of ash per day if no safeguards is adopted. All steam-generating plants also discharge nearly 60% of heat produced back to the atmosphere irrespective of the fuel used.

Due to large emissions from the thermal power plants, air pollution has become an international problem. This problem is mainly faced by 11 countries in the world, which share 80% of the world's fossil-fired generating capacity. Emissions from their power plants have grown to point where we and all of them now must think for controlling the pollution contributing to a common atmosphere. Many countries have unique air pollution problems. These are due to fuel characteristics, unfavorable topographical conditions, concentration of power plants in limited area and high population densities. The production capacities of 11 countries, which share 80% world-electric generation. The major pollutants given off by fossil fuel combustion are particulates, SO<sub>2</sub> and other gases and it will be sufficient to discuss about these pollutants.

## **WATER POLLUTION BY THERMAL POWER PLANTS**

Another serious problem is the water pollution caused by thermal power plants. The water pollution is caused by discharging hot condenser water and water discharged into the river carrying the ash of the plant. The discharge of polluted water causes hydrological and biological effects on the surrounding ecology. The biological study should determine the types of aquatic organisms in the area and their adaptability to the environmental variations.

Thermal pollution of water is very important for the fish cultivation, as their growth is very susceptible to the temperature changes.

Another important constituent in the discharge of cooling water is residual chlorine as chlorine or sodium hypochlorite is used to prevent fouling of the condensers.



Another serious problem associated with the discharged water is the ash carried by the water. The ash gets spread over the large cultivated area along the path of the river and affects the agricultural growth very much. This is because; the ash has high alkaline characteristics, which are injurious for the growth of many agricultural products. The ash destroys the fertility of the land forever. Such phenomenon was badly experienced when the ash from Koradi thermal power station in Maharashtra was discharged in the river. The wastewater from water demineralization plant contains large quantities of chlorides of Ca, Mg, Na and K. This wastewater is channeled out to some river or to an ash pond along

POLLUTION AND ITS CONTROL 429  
 the fly ash. On the way to river or ash pond, these salts percolate in the nearby soil and make the ground water salty. In the ash pond, the situation is worse as there is continuous accumulation of these salts and the pond reaches a saturation level of these salts. The process of salt saturation in the pond is further accelerated by solar evaporation of the water. The wells on the area covering a few kilometers from the ponds become salty and polluted water from these wells becomes harmful for human consumption as well as for irrigation purposes. Discharging these salts with the wastewater aggravates the pollution problem but also loses them, even though; their recovery is simple and economical. The wastewater can be treated first with lime, to precipitate magnesium hydroxide and then with soda ash to get precipitated calcium carbonate and the resulting sodium chloride solution can be reused for regeneration of softeners. The above-mentioned reactions are listed below.

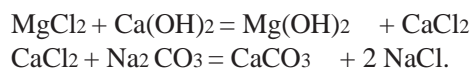

## ENVIRONMENT CONCERNS AND DIESEL POWER PLANTS

With the emergence of liquid fuel based power stations in India, the question of environment pollution has become a matter of raging debate. The coal based thermal power stations, in its earlier stages of inception, were far more polluting? It was because of the combination of sulphur-based pollutants, nitrogen based gaseous matter and also particulate matter with very high ash content being released in the atmosphere.

Globally, environmental regulatory authorities are increasingly concerned with NO<sub>x</sub> and SO<sub>x</sub> emissions and are liable to consider introducing stringent regulatory standards in the future. While the levels of SO<sub>x</sub> emissions is the function of sulphur content inherited in the fuel being used for combustion? NO<sub>x</sub> is created by the chemical activity between atmospheric oxygen and nitrogen during combustion. The level of NO<sub>x</sub> depends on the combustion conditions.

Optimal combustion in a diesel engine depends upon the achievement of the right balance of equation between compression/combustion pressure, compression ratio, air-to-fuel ratio and mean effective

pressure. The toughest of the emission standards currently being considered by various national and international agencies, calls for limitation of NO<sub>x</sub> emissions to 600 ppm(15% O<sub>2</sub>) for generator sets operating on ocean bound vessels. The shore-based power stations shall demand for further lower limits due to proximity to the human inhabitation.

Burning heavy fuel in diesel engine is convenient mainly due to economics of residual fuel combustion for power generation. Diesel engine designers' world over will increasingly come under pressure to introduce superior combustion features for producing lower levels of SO<sub>x</sub> and NO<sub>x</sub>.

The exhaust gas composition of emissions or pollutants given above is for using furnace oil of different grades and varying sulphur contents. The exhaust gas of medium speed engines comprises of a host of constituents. In the case of combusting heavy fuel like furnace oil, these emanate either from combustion air and fuel used, or they are reaction products, which get formed during the combustion process. Only some of these are considered to be pollutants for the atmosphere:

### Typical Exhaust Gas Emission Values For Modern 4-stroke Diesel Power Plants Using Heavy Fuel Fuel FO-kV(2.1% sulphur) FO (4.5% sulphur)

|                               |       |       |
|-------------------------------|-------|-------|
| Load(%)                       | 100.0 | 100.0 |
| Mech, output (kW/cyl.)        | 990.0 | 990.0 |
| Speed (rpm)                   | 500.0 | 500.0 |
| O <sub>2</sub> (volume %,dry) | 12.7  | 12.9  |

NO<sub>x</sub> (ppm,dry, 15% O<sub>2</sub>) 1045.0 1600.0  
 CO (ppm,dry, 15% O<sub>2</sub>) 60.0 95.0  
 HC (ppm,dry, 15% O<sub>2</sub>) 155.0 155.0  
 SO<sub>2</sub> (ppm,dry, 15% O<sub>2</sub>) 405.0 1200.0  
 TSP(mg/m<sup>3</sup>,15% O<sub>2</sub>) 65.0 90.0

**Carbon dioxide (CO<sub>2</sub>):** CO<sub>2</sub> actually is not noxious as a product of combustion of all fossil fuels. It is now considered to be one of the main causes of the greenhouse effect. A reduction of CO<sub>2</sub> emission can only be achieved by improving the engine efficiency or by using fuels containing lower concentration of carbon such as natural gas.

**Sulphur oxides (SO<sub>x</sub>):** Sulphur oxides are formed due to the combustion of sulphur contained in the fuel. They are one of the primary causes of acid rain. The sulphur oxide emission is primarily influenced by the amount of sulphur contained in the fuel used. Much less influence can be taken by the fuel consumption of engine. The major part (> 95%) of sulphur oxides contained in the exhaust gas of the diesel engines is SO<sub>2</sub>.

**Nitrogen oxides NO<sub>x</sub> (NO, NO<sub>2</sub>, N<sub>2</sub>O):** Nitrogen oxides which are generally referred to as NO<sub>x</sub> in the case of internal combustion engines comprise nitrogen monoxide-NO (colourless, water insoluble gas), nitrogen dioxide-NO<sub>2</sub> (reddish brown gas, highly toxic) and dinitrogen monoxide-N<sub>2</sub>O (laughing gas, colourless gas previously used as a narcotic). Nitrogen oxides, together with the sulphur oxides are the main causes of acid rain. They also contribute essentially to ozone formation in the air and ground level. The high temperatures and pressures produced in the combustion space of an IC engine stimulate the nitrogen content in the air and also in the grades used (such as heavy fuel oil) to react with oxygen in the combustion air. In this reaction mechanism, the formation of nitrogen oxides proportionally increases with the temperature rise. This behavior unfortunately combats the efforts of improving on engine efficiency because conversion of energy at the highest possible temperature level is to be aimed for to reach the optimal efficiencies of combustion processes.

The NO<sub>x</sub> formation during combustion in the diesel engine is predominantly NO and which is converted to a minor extent to NO<sub>2</sub> by oxidation either in the combustion space or in the exhaust gas systems downstream (exhaust gas piping, exhaust gas turbo charger etc.). In general, exhaust gas leaving the engine is 95% NO and approximately 5% NO<sub>2</sub>. To simulate the process of NO oxidation, to form NO<sub>2</sub> in the atmosphere, practically, all the legislation stipulate that in the calculation of NO<sub>x</sub> mass flow emitted, the entire NO<sub>x</sub> must be taken as NO<sub>2</sub>. The N<sub>2</sub>O concentration in the exhaust gas of medium speed diesel engines, burning heavy fuel is limited to a few ppm. Therefore, it can be neglected from the viewpoint of environmental protection.

POLLUTION AND ITS CONTROL 431

**Carbon Monoxide (CO):** It is a colourless, highly noxious gas which forms where the combustion of fuels containing carbon proceeds under (possibly local) air starvation. In modern DG sets, optimisation of air/fuel mixture formation and use of constant pressure type turbo charging, successfully reduces the CO content of exhaust gases even with the poorest qualities of fuel grades. This type of engine design meets even the stringent standards set by such environmental agencies like TA-Luft of Germany.

**Non combusted Hydro carbons(HC):** Hydro carbons contained in the exhaust gas consists of a multitude of various organic compounds. However, the HC contents of exhaust gases for modern 4-stroke diesel engines burning heavy fuel are very low and are not a matter of environmental debate.

**Soot, Dust:** Solids contain in exhaust gases of diesel engines burning heavy fuel not only consist of soot (carbon) resulting due to incomplete combustion of the fuel but also due to dust and ash particles from the fuel and the lube oil, the quality of the combustion air and from the abrasion products. Even though, these constitutes the major source of visible dark coloration, of exhaust gases, soot particles only account for a relatively low percentage of total dust concentration. Based on the ash content of the fuel and the lube, the soot quantity also varies as shown in the table below.

**Fuel Gas Oil Heavy Fuel Oil**

Ash content — Fuel% 0.01 0.10  
 Ash content — Lube% 1.50 4.00  
 Soot (Carbon) mg/m<sup>3</sup> 15.00 15.00  
 Fuel ash mg/m<sup>3</sup> 4.00 40.00  
 Lube oil ash mg/m<sup>3</sup> 3.00 8.00

Overall analysis of environmental laws will take us into two pronged environmental considerations.

**I.** Long term consideration on implementation of actual system emission limits. This should take

into account existing technology, cost competitiveness, consideration to burn only low grade, tertiary fuels, demand technology life-cycle, nature of project and plant gestation and country objectives.

**II.** Short term aspects mainly centred on maintaining desired ambient air qualities. This will bring us to the debate emission levels. The ground level dispersion of emission components are easily met far below existing standards by the modern 4-stroke diesel engines while burning heavy fuel. In view of the above, adequate chimney/stack heights for guiding the exhaust gases away from the ground level can easily ensure low dispersions at ground level after emission at relevant designed chimney heights based on sulphur contents in the fuel.

## NUCLEAR POWER PLANT AND THE ENVIRONMENT

In the United States, and doubtless in almost all countries constructing nuclear power plants, federal licensing proceedings for each plant require the inclusion of detailed environmental statements to be issued as public documents. In the United States, these should be in accordance with the National Environmental Policy Act of 1969 (NEPA). Such statements must assess not only the impact upon the environment that is associated with the construction and the operation of the power plant, but also the effect of the transportation of radioactive materials to and from that plant.

Besides thermal pollution, which it shares with almost all types of power plants, nuclear power's effects on the environment stem mainly from

- (1) the nuclear fuel cycle,
- (2) low-level dose radiations from nuclear-power plant effluents, and (3) low and high-level dose radiations from wastes.

## THE FUEL CYCLE

Most nuclear power plants in operation or under construction in the world today are using, and will continue to use for the near future, ordinary (light) water cooled and moderated reactors: the Pressurized

Water Reactor (PWR) and the Boiling Water Reactor (BWR). A small number use the heavy water cooled and moderated reactor (PHWR). The expectations are that the fast-breeder reactor power plant and perhaps an improved version of the gas-cooled reactor power plant will come on line in increasing numbers in the twenty-first century. Almost all-current water reactors use slightly enriched uranium dioxide,  $UO_2$ , fuel. The fuel has to go through a cycle that includes prereactor preparation, called the front end, in-reactor use, and post reactor management, called the back end.

**Fig. 13.4.** A typical nuclear fuel cycle (a) with reprocessing and (b) without reprocessing.

The different process are briefly explained below:

1. Mining of the uranium ore.
  2. Milling and refining of the ore to produce uranium concentrates,  $U_3O_8$ .
  3. Processing to produce of uranium hexafluoride,  $UF_6$ , from the uranium concen-trates. This provides feed for isotopic ( $U_{235}$ ) enrichment.
  4. Isotopic enrichment of uranium hexafluoride to reach reactor enrichment require-ments. This is done invariably now by the gaseous diffusion process.
  5. Fabrication of the reactor fuel elements. This includes conversion of uranium hexafluoride to uranium dioxide  $UO_2$ , pelletizing, encapsulating in rods, and assembling the fuel rods into subassemblies.
  6. Power generation in the reactor, resulting in irradiated or spent fuel.
  7. Short-term storage of the spent fuel.
  8. Reprocessing of the irradiated fuel and conversion of the residual uranium to uranium hexafluoride,  $UF_6$  (for recycling through the gaseous diffusion plant for reenrichment) and/or extraction of  $Pu_{239}$  (converted from  $U_{238}$ ) for recycling to the fuel-fabrication plant. Reprocessing can reuse up to 96 percent of the original material in the irradiated fuel with 4 percent actually becoming waste.
  9. Waste management, which includes long-term storage of high-level wastes.
- Step 8, reprocessing, may be bypassed, which results in disposal of both reusable fuel and wastes. This is the current (1982) U.S. Department of Energy process for dealing with irradiated fuel. The fuel assemblies are stored for at least 10 years and then buried. This is the so-called throw-away fuel cycle.

## WASTES

The wastes associated with nuclear power can be summarized as:

**1. Gaseous effluents.** Under normal operation, these are released slowly from the power plants into the biosphere and become diluted and dispersed harmlessly.

**2. Uranium mine and mill tailings.** Tailings are residues from uranium mining and milling operations. They contain low concentrations of naturally occurring radio-active materials. They are generated in large volumes and are stored at the mine or mill sites.

**3. Low-level wastes (LLW).** These are classified as wastes that contain less than 10 nCi (nanocuries) per gram of transuranium contaminants and that have low but potentially hazardous concentrations

of radioactive materials. They are generated in almost all activities (power generation, medical, industrial, etc.) that involve radioactive materials, require little or no shielding, and are usually disposed of in liquid form by shallow land burial (Fig. 13.5).

**4. High-level wastes (HLW).** These are generated in the reprocessing of spent fuel. They contain essentially all the fission products and most of the transuranium elements not separated during reprocessing. Such wastes are to be disposed of carefully.

**5. Spent fuel.** This is unprocessed spent fuel that is removed from the reactor core after reaching its end-of-life core service. It is usually removed intact in its fuel element structural form and then stored for 3 to 4 months under water on the plant site to give time for the most intense radioactive

434 POWER PLANT ENGINEERING

isotopes (which are the ones with shortest half-lives) to decay before shipment for reprocessing or disposal. Lack of a reprocessing capacity or a disposal policy has resulted in longer on-site storage, however. If the spent fuel is to be disposed of in a throwaway system (without reprocessing), it is treated as high-level waste.

## RADIATIONS FROM NUCLEAR-POWER PLANT EFFLUENTS

Radiations from nuclear-power plant effluents are low-dose-level types of radiations. The effluents are mainly gases and liquids. Mainly the effects of these radiations on the populations living near the plants prompt environmental concerns about nuclear power plants. Sources of effluents vary with the type of reactor.

In both pressurized-water reactors (PWR) and boiling-water reactors (BWR), two important sources of effluents are

(1) The condenser steam-jet air ejectors and

(2) The turbine gland-seal system.

The ejector uses high-pressure steam in a series of nozzles to create a vacuum, higher than that in the condenser, and thus draws air and other non-condensable gases from it. The mixture of steam and gases is collected, the steam portion condenses, and the gases are vented to the atmosphere. In the gland seal, high-pressure steam is used to seal the turbine bearings by passing through a labyrinth from the outside in so that no turbine steam leaks out and, in the case of low-pressure turbines, no air leaks in. The escaping gland-seal steam is also collected and removed. In the BWR, the effluents come directly from the primary system. In the PWR, they come from the secondary system, so there is less likelihood of radio-active material being exhausted from a PWR than a BWR from these sources.

The primary-coolant radioactivity comes about mainly from fuel fission products that find their way into the coolant through the few small cracks that inevitably develop in the very thin cladding of some fuel elements. Such activity is readily detectable. However, to avoid frequent costly shutdowns and repairs, the system is designed to operate as long as the number of affected fuel elements does not exceed a tolerable limit, usually 0.25 to 1 percent of the total. Also, some particulate matter finds its way into the coolant as a result of corrosion and wear (erosion) of the materials of the primary system components.

These become radioactive in the rich neutron environment of the reactor core. Corrosion occurs because the radiolytic decomposition of the water passing through the core results in free O<sub>2</sub> and free H and OH radicals as well as some H<sub>2</sub>O<sub>2</sub>. These lower the pH of the coolant and promote corrosion. Finally, radioactivity in the primary coolant may be caused by so-called *tramp uranium*. This is uranium or uranium dioxide dust that clings to the outside of the fuel elements and is insufficiently cleaned off during fabrication. It will, of course, undergo fission, and its fission products readily enter the coolant. Improved processing and quality control are minimizing the problem of tramp uranium.

### 13.19 IMPACT ON POLLUTION LOAD AND AIR QUALITY IN DELHI

The major impacts have been observed through the implementation of emission norms and fuel quality specifications effective from 1996, as also phasing out of 15-year-old commercial vehicles and leaded petrol in the year 1998 and phasing out of 8-year-old commercial vehicles and 15-year-old two wheelers from 2000 onwards. The ambient air quality as monitored by CPCB during 1999 shows reduction in levels of various pollutants in ambient air as compared to previous year. The reducing trend was observed with respect to Carbon Monoxide, nitrogen dioxide, and lead in residential areas.

#### ENVIRONMENTAL CONCERNS

In Delhi today, pollution is one of the most critical problems facing the public and concerned authorities. According to the World Health Organization (WHO), Delhi is the fourth most polluted city in the world in terms of suspended particulate matter (SPM). The growing pollution is responsible for increasing health problems. The deteriorating environment is the result of population pressure and haphazard

growth. Industrial development has been haphazard and unplanned. Only about 20% of the industrial units are in approved industrial areas; the remainders are spread over the city in residential and commercial areas. Road transport is the sole mode of public transport; there has been a phenomenal increase in the vehicle population, which has increased from 2 lakhs in 1971 to 32 lakh in 1999.

#### POLLUTION LEVELS

**1. Ambient Air Quality.** Data from continuous monitoring of air quality reveals that while suspended particulate matter levels still far exceed stipulated standards, there is a significant downward trend.

Noise levels in Delhi exceed permissible levels in all areas except industrial areas, according to a study by the Delhi Pollution Control Committee. Since noise is measured on a logarithmic scale, an increase of every 3-5 dBA has twice the effect on humans. Diesel generating sets and vehicles, particularly auto-rickshaws, have been identified as major sources of noise pollution in Delhi.

**2. Air Pollution.** The 1991 report by the National Environmental Engineering Research Institute (NEERI), Nagpur documents the amount of pollution that is contributed by different sectors in Delhi. In relative terms, the quantum of industrial air pollution has decreased over the years. However, vehicular pollution has increased rapidly. The drop in share of domestic air pollution is due to the increased number of LPG connections in Delhi, which have replaced other forms of fuel.

**3. Water pollution.** The 48-km stretch of the Yamuna River in Delhi is heavily polluted by domestic and industrial wastewater. The river water upstream of Wazirabad is fit for drinking after it has been treated, but after the confluence of the Najafgarh drain and 18 other major drains, the water quality becomes heavily degraded and is unfit even for animal consumption and irrigation.

**4. Domestic Wastewater Pollution.** The increase in population has resulted in a corresponding increase in the volume of domestic wastewater that is generated. Sewage treatment capacity is about 344 MGD at present against about 470 MGD wastewater that is generated each day in Delhi. The sewage treatment capacity is not fully utilized due to malfunctioning of the trunk sewer system.

**5. Industrial Wastewater.** The industrial wastewater generated in Delhi is about 70 MGD. Although some industrial units have provided facilities to treat wastewater, most small-scale industries do not have such facilities.

436 POWER PLANT ENGINEERING

**6. Vehicular Pollution.** The steep increase in vehicle population has resulted in a corresponding increase in pollutants emitted by vehicles. Petrol consumption has increased from 133 thousand tons in 1980-81 to 449 thousand tons in 1996-97 and HSD consumption from 377 thousand tons to 1,234 thousand tons. Two-wheelers, which constitute 66% of the vehicles registered in Delhi, are the major source of air pollution.

**7. Solid Waste.** NEERI estimates indicate that about 8000 M. Tonnes of solid waste is being generated each day in Delhi at present. In addition, industrial hazardous and non-hazardous waste, such as fly ash from power plants, is also generated. MCD and NDMC could manage to clear about 5000-5500 M. Tonnes of garbage each day resulting in accumulation of garbage in the city area.

**8. Hospital Waste Pollution.** With the increase in the number of hospitals and nursing homes in Delhi, hospital waste has become another area of concern. Private nursing homes and small hospitals do not have arrangements to treat hospital waste. Installing incinerators to burn hospital waste is not an ideal solution since these incinerators add to air pollution.



## MEASURES TO COMBAT POLLUTION

**1. Vehicular Pollution.** Delhi has more vehicles than the three metropolitan cities of Mumbai, Calcutta and Chennai combined. It is the only metropolitan city where commuters are primarily dependent on a single transport system, i.e., road. This has led to an enormous increase in the number of vehicles with the associated problems of traffic-congestion and increase in air and noise pollution. There is an urgent need to strengthen and encourage use of public transport including development of MRTS and better utilization of the existing ring railway.

The Delhi Government has started an incentive scheme to replace old commercial vehicles. The supply of lead-free petrol in Delhi since April 1998 has brought down the lead content in the air. The promotion of CNG as a fuel for buses, cars, taxis and auto-rickshaws is being considered as a method of reducing the level of vehicular pollution. Replacement of old commercial vehicles, no registration of army and government disposed old vehicles, etc. measures also contributed to some extent.

**2. Pollution from Thermal Power Plants.** Thermal power plants contribute to 13% of air pollution. The main pollutants are stack emissions; fly ash generation and fugitive emission in coal handling. All three thermal power plants need better use of their emission control devices and the fly ash that they generate. There is an immediate need to use beneficiated/washed coal, which has a maximum ash content of 30%, which will reduce fly ash generation by about 25%. It has also been recommended to the Thermal Power Stations to examine the possibility of installing Bag House Filters in order to control emission of particles between the size of PPM 2.5 to PPM-10.

**3. Industrial Air Pollution.** The air pollution generated from industrial activity in Delhi is about 12% of total air pollution. Although several steps have been taken, industrial pollution needs to be reduced further. More than 1,300 industrial units, that were not allowed to operate under the MPD-2001 norms, have been closed. A scheme has been prepared to relocate industrial units that currently operate in residential areas. About 1,300 acres of land have been acquired and new industrial estates are being developed at Bawana, Holumbi Kalan and Holumbi Khurd. Land available within existing industrial estates is also being used to accommodate such industrial units. Anand Parbat, Shahdara and Samaipur Badli area are being developed as industrial areas. All industries in Delhi using Coal Fired Boilers have been asked to change over to Oil or Gas Fired Boilers in order to reduce air pollution generated from industrial activities. This will also reduce the Fly Ash generated by the approximate 4000-5000 coal fired boilers in the City. All industries are also being advised to control pollution from diesel generating

sets. They have been asked to increase the stack height to a level of 2-3 meters above their building height and also take acoustic measures to reduce the noise level from diesel generating sets.

**4. Industrial Wastewater Pollution.** There are 28 industrial areas in Delhi. Most of the small and tiny industries do not have individual facilities to treat liquid waste. The Hon'ble Supreme Court has ordered that 15 Common Effluent Treatment Plants (CETPs) be constructed. All water-polluting industries in Delhi have been directed to comply with orders of the Hon'ble Supreme Court and ensure that they do not discharge untreated effluent. Action has been taken against 2,300 industrial units in Delhi so far (January, 2000) and is continuing to cover all such water polluting units. Each unit has been asked to install an Effluent Treatment Plant to ensure neutralization of acidity, removal of oil and grease and removal of total suspended solids to the levels specified for each industry by the Central Pollution Control Board or up to sewage standards wherever specific standards have not been laid down.

The breakdown of funding for the CETPs is given below:

- (a) 25% by the Delhi Government
- (b) 25% by the Government of India
- (c) 20% by concerned industries through the CETP society, and
- (d) 30% loan financed by IDBI.

The cost of constructing 15 CETPs which was estimated at Rs. 90 crore in 1996-97 is now estimated at about Rs. 190 crore. Progress has been slow due to reluctance on the part of industrial units to contribute their share.

**5. Domestic Wastewater Pollution.** The present water supply capacity in Delhi is approximately 591 MGD and the sewage treatment capacity is 344 MGD. 16 new sewage treatment plants are at various stages of commissioning and construction. Of the 16 plants, 5 were completed by March 1999, 8 will be completed in 1999-2000 and one in 2000-01. However, since unauthorized colonies and JJ clusters may not be provided with sewerage systems, wastewater from these areas will continue to be discharged through drains. Accordingly, a parallel channel from Wazirabad to Okhla has been proposed.



Water and Power Consultancies Services (WAPCOS) are doing the feasibility study for the proposed channel.

**6. Industrial Non-hazardous Waste Management.** The main industrial non-hazardous waste is fly ash from power plants that emit about 6,000 metric tons of fly ash per day. Until recently, the fly ash was disposed off for earth filling apart from about 100 metric tons per day that was used to manufacture

pozzolana cement. A small quantity of fly ash near BTPS is also used to manufacture bricks. Land is now being allotted to three brick manufacturing units near Rajghat and Indraprastha thermal power stations so that additional fly ash from these plants can be utilized. At the same time, the use of beneficiated/

washed coal may reduce the amount of fly ash generated by thermal power plants.

**7. Hazardous Waste Management.** The National Productivity Council, New Delhi has conducted an Environment Impact Assessment study to select a site for the disposal of hazardous waste. A 150 acre site on the Bawana-Narela Road was selected but it has not been made available due to opposition from local residents.

**8. Solid Waste Management.** The management of solid waste in Delhi is being improved through measures adopted by concerned agencies. The measures include the following:

- (1) Construction of dalaos/dustbins;
- (2) Purchase of additional front-end loaders, refuse collectors, mechanical sweepers, tipper trucks, dumper placers, etc.;

438 POWER PLANT ENGINEERING

- (3) Use of garbage to make compost with the participation of the private sector;
- (4) Development of new sanitary land-fill sites;
- (5) Disposal of garbage at the local area level through vermin composting.
- (6) Involvement of NGOs and Resident Welfare Association in segregation and collection of garbage from houses.

**9. Hospital Waste Disposal.** The Delhi Government has constituted a committee to implement the Bio-Medical Waste (management and handling) Rules, 1998. Almost all government hospitals have installed incinerators for the disposal of hospital waste. Sanjay Gandhi Memorial (SGM) Hospital has also installed an autoclave that is used for 97% of its waste disposal. The Centre for Occupational and Environmental Health (COEH) is helping the committee monitor the progress of the programme and ensure that the Bio-Medical Waste Rules 1998 are implemented by all hospitals in Delhi.

**10. Other Measures.** Several other measures are being taken to control pollution and improve the environment. These include:

- (1) Planting of 21 lakh trees/shrubs in 1999-2000;
- (2) Public awareness campaigns;
- (3) Setting up eco-clubs in schools;
- (4) Development and protection of the Ridge area;
- (5) Development of a wildlife sanctuary at Bhati-Asola;
- (6) Development of old lakes;
- (7) 10 City Forest Sites have been identified by the Forest Department. These will be developed by the Forest Department as 'Green Lungs' for various areas.

The Delhi Plastic (Manufacture, Sale and Usage) and Non-Biodegradable Garbage (Control) Bill, 1999 has been moved in the Legislative Assembly for banning the use of plastic bags for food items. This has been referred to a Select Committee of the House in the December 1999 Session of the Legislative Assembly.

## METHOD FOR POLLUTION CONTROL

The following methods for developing the power generating capacity without pollution to the atmosphere.

1. F.P. Rogers has suggested that it would be safer to set the nuclear power plants underground. This definitely preserves the environment. There would be lot of difficulties in excavation, concreting, roof lining, structural supporting, lowering the reactor equipments and many others. But even then it is suggested that locating the power plant underground would be profitable in the long run.
2. The tidal power must be developed in the coining years that is free from pollution.
3. The thermal discharges to the environment are common from fossil and nuclear-fueled power

stations. Significant quantities of particulates and gases from fossil-fueled system, small quantities of radioactive gases from nuclear, have an impact upon an environment. Offshore siting of power plants mitigates these problems of pollution. Offshore siting of power stations also isolates the plants from earthquakes and provides the thermal enhancement of the water to increase recreational and commercial values. No doubt, offshore location requires new design consideration and floating platforms in the sea increasing the capital cost of the plant.

4. It was proposed that the thermal pollution of the atmosphere and the generation cost of the plant could be reduced by using the low-grade energy exhausted by the steam. The ideal use for enormous quantity of residual energy from steam power plants requires large demand with unity power factor.

Particularly in U.S.A., many uses of energy are available in winter, but not in summer therefore finding large-scale valuable uses of thermal energy is the key for developing beneficial uses.

It is estimated that the total energy used in U.S.A. for air-conditioning is equivalent to the total energy used for heating the offices and residences. The low-grade energy exhaust by the thermal plants is not readily usable for air-conditioning purposes. It is possible to use this energy by stopping the expansion of steam at a temperature of 95°C to 100°C and use of this energy can be made to drive an absorption refrigeration system such as lithium bromide water system. This will be a definite positive answer to reduce the thermal pollution of environment otherwise caused by burning extra fuel to run the absorption refrigeration system in summer or to run the heating systems in winter.

As for open field irrigation, soil heating with warm water and better cultivation of the fishes in slightly warm water. In short, a combination of uses could consume all heat from a large thermal power station, making conventional cooling unnecessary and reduce the generating cost with minimum thermal pollution of the atmosphere.

5. Use the sun energy for the production of power that is absolutely free from air-pollution.

## **CONTROL OF MARINE POLLUTION**

Demographic pressure and rapid industrialisation has led to increased generation of wastes, and, these wastes reach the sea either directly or indirectly through rivers. This has caused pollution in the marine environment particularly in the coastal waters. Besides these sources, release of agricultural wastes containing pesticide residues and operational releases of ships and tankers containing oil, also cause pollution in the marine environment.

In order to monitor the levels of marine pollutants in a systematic manner as well as to quantify their transport rates from land-based sources to the sea, a well-knit multi institutional programme on Environmental Monitoring and Modelling has been launched by establishing an Apex Centre at Regional Centre, National Institute of Oceanography, Bombay and ten units at expert institutions such as NIO, Goa and its regional centres at Cochin and Waltair, Central Salt and Marine Chemicals Research Institute (Bhavnagar), Centre for Earth Science Studies (Trivandrum), units of Central Electrochemical Research Institute at Tuticorin and Madras, Regional Research Laboratory (Bhubaneswar), Zonal Office, Central Pollution Control Board (Calcutta) and the DOD Centre in the Andaman and Nicobar Islands. As a supportive measure for the development of suitable methodology on monitoring and modelling, DOD supported cells at Centre for Mathematical Modelling and Computer Simulation (Bangalore), Regional Research Laboratory (Trivandrum) and National Environmental Engineering Research

Institute (Nagpur), have also been established. The programme, after considerable amount of generation of data, is expected to provide knowledge on behaviour of pollutants in the sea and trends on fluctuation of pollutants in the sea, which will be useful in the pollution abatement measures.

## **REFERENCE BOOKS**

1. Power Plant Engg. by S. Domkundwar, Dhanpat Rai & Sons.
2. Power Plant Engg. by R. K. Rajput, Sultan Chand Pub.
3. Power Plant Engg by A.K Raja, Amit Prakash Srivastava & Manish Dwivedi, New Age International Publishers